**Getting started with STM32MP151, STM32MP153
and STM32MP157 line hardware development**

Introduction

This application note shows how to use the STM32MP151, STM32MP153 and STM32MP157 lines, and describes the minimum hardware resources required to develop an application based on those MPU products.

This application note is intended for system designers who require an overview of the hardware implementation of the development board, with focus on features like:

- Power supply
- Package selection
- Clock management
- Reset control
- Boot mode settings
- Debug management.

Reference design schematics are also contained in this document with descriptions of the main components, interfaces and modes.

Contents

1	General information	8
2	Reference documents	8
3	Glossary	9
4	Power supplies	11
4.1	Introduction	12
4.1.1	Independent ADC and DAC converter supply and reference voltage	12
4.1.2	Battery backup	13
4.1.3	Voltage regulators	13
4.2	Power supply schemes	14
4.3	Reset and power supply supervisor	17
4.3.1	Power on reset (POR) / power down reset (PDR)	17
4.3.2	Programmable voltage detector (PVD)	17
4.3.3	Application and system resets	18
5	Packages	20
5.1	Package selection	20
5.2	Alternate function mapping to pins	22
5.3	Package compatibility between versions	23
6	Clocks	28
6.1	HSE OSC clock	28
6.1.1	External source (HSE bypass)	29
6.1.2	External crystal/ceramic resonator (HSE crystal)	29
6.2	LSE OSC clock	30
6.2.1	External source (LSE bypass)	30
6.2.2	External crystal/ceramic resonator (LSE crystal)	30
6.3	Clock security system (CSS)	31
6.3.1	CSS on HSE	31
6.3.2	CSS on LSE	31
7	Boot configuration	32

7.1	Boot mode selection	32
7.2	Boot pin connection	33
7.3	Embedded boot loader mode	35
8	Debug management	36
8.1	Introduction	36
8.2	SWJ debug port (serial wire and JTAG)	36
8.3	Pinout and debug port pins	36
8.3.1	Internal pull-up and pull-down resistors on JTAG pins	36
8.3.2	Debug port connection with standard JTAG connector	37
8.3.3	Debug port and UART connection with STDC14 connector	38
8.3.4	Parallel trace and HDP	39
8.3.5	Debug triggers and LEDs	41
9	Recommendations	42
9.1	Printed circuit board	42
9.2	Component position	42
9.3	Ground and power supply (V_{SSx} , V_{DDx})	42
9.4	IO speed settings	42
9.5	PCB stack and technology	46
9.6	Decoupling	50
9.7	ESD/EMI protections	50
9.8	Sensitive signals	51
9.9	Unused I/Os and features	51
10	Reference design examples	52
10.1	Description	52
10.1.1	Clock	52
10.1.2	Reset	53
10.1.3	Boot mode	53
10.1.4	SWD / JTAG interface	53
10.1.5	Power supply	54
10.1.6	DDR3/DDR3L SDRAM	57
10.1.7	LpDDR2/LpDDR3 SDRAM	58
10.1.8	SD card	59
10.1.9	eMMC™ Flash	61

10.1.10	SLC NAND-Flash	63
10.1.11	Serial NOR-Flash/NAND-Flash	64
10.1.12	USB	66
10.1.13	Ethernet	69
10.1.14	Display serial interface (DSI)	74
11	Revision history	77

List of tables

Table 1.	Reference documents.....	8
Table 2.	Glossary.....	9
Table 3.	Recommended settings for ANASWVDD and EN_BOOSTER.....	13
Table 4.	Amount of decoupling recommendation by package.....	16
Table 5.	Package summary.....	20
Table 6.	Major feature changes related to packages.....	21
Table 7.	Device compatibility summary.....	23
Table 8.	STM32MP151xxx and STM32MP153xxx for 16x16 LFBGA354 compatibility.....	24
Table 9.	STM32MP151xxx and STM32MP153xxx for 10x10 TFBGA257 compatibility.....	25
Table 10.	STM32MP151xxx and STM32MP153xxx for 12x12 TFBGA361 compatibility.....	26
Table 11.	STM32MP151xxx and STM32MP153xxx for 18x18 LFBGA448 compatibility.....	27
Table 12.	Boot modes.....	32
Table 13.	OSPEEDR setting example for VDD = 3.3 V typ.....	43
Table 14.	OSPEEDR setting example for VDD = 1.8 V typ.....	44
Table 15.	HSE BOM for oscillator or crystal.....	52
Table 16.	UART possible boot pins.....	53
Table 17.	USB package length matching values.....	68
Table 18.	DSI package length matching values.....	75
Table 19.	DSI PCB routing recommendations.....	76
Table 20.	Document revision history.....	77

List of figures

Figure 1.	Power supply scheme	11
Figure 2.	Power-on reset/power-down reset waveform	17
Figure 3.	PVD thresholds	18
Figure 4.	Simplified reset pin circuit	19
Figure 5.	STM32CubeMX example screen-shot	22
Figure 6.	16x16 LFBGA354 compatibility	24
Figure 7.	10x10 TFBGA257 compatibility	25
Figure 8.	12x12 TFBGA361 compatibility	26
Figure 9.	18x18 LFBGA448 compatibility	27
Figure 10.	HSE external clock	28
Figure 11.	HSE crystal/ceramic resonators	28
Figure 12.	LSE external clock	30
Figure 13.	LSE crystal/ceramic resonators	30
Figure 14.	Boot mode selection example	33
Figure 15.	BOOT pins typical connection schematics	34
Figure 16.	Simplified boot flow	35
Figure 17.	Host-to-board connection	36
Figure 18.	JTAG/SWD MIPI10 connector implementation example	37
Figure 19.	JTAG/SWD/UART VCP STDC14 connector implementation example	38
Figure 20.	Parallel trace port with JTAG/SWD on Mictor-38 implementation example	40
Figure 21.	Example of LED connections	41
Figure 22.	IO speed summary with various loads and voltages	43
Figure 23.	6 layer PCB stack example	46
Figure 24.	4 layer PCB stack example	47
Figure 25.	PCB rule example for 0.8 mm pitch package	48
Figure 26.	PCB rule example for 0.5 mm pitch package	49
Figure 27.	PCB rule example for inner balls with 0.65mm power improved pitch	49
Figure 28.	Exemple of decoupling layout	50
Figure 29.	HSE recommended schematics for both oscillator/crystal options	52
Figure 30.	Discrete supplies example 3.3 V I/Os with DDR3L	54
Figure 31.	PMIC example 3.3 V I/Os with DDR3L	55
Figure 32.	PMIC example 1.8 V I/Os with LPDDR2/LPDDR3	56
Figure 33.	DDR3L 16/32 bits connection example	57
Figure 34.	LPDDR2/LPDDR3 32-bits connection example	58
Figure 35.	SD-Card with external level shifter connection example	60
Figure 36.	SD-Card with 3.3 V I/Os connection example	61
Figure 37.	eMMC™ connection example	62
Figure 38.	SLC NAND-Flash connection example	63
Figure 39.	Serial Flash connection example	64
Figure 40.	Dual-Serial Flash connection example	65
Figure 41.	USB 2 ports host high-speed + OTG full-speed connection example	66
Figure 42.	USB host high-speed + OTG high-speed connection example	67
Figure 43.	USB high speed PCB track example for 0.8 mm ball pitch package	68
Figure 44.	10/100M Ethernet PHY connection example	69
Figure 45.	10/100M Ethernet PHY connection with REFCLK from RCC example	70
Figure 46.	Gigabit Ethernet PHY connection example with VDD = 3.3 V (RTL8211E)	71
Figure 47.	Gigabit Ethernet PHY connection example with VDD = 3.3 V (RTL8211F)	72
Figure 48.	Gigabit Ethernet PHY connection example with VDD = 1.8 V (RTL8211F)	72

Figure 49. Gigabit Ethernet 2-port switch example with VDD = 3.3 V (RTL8363NB-VG)	73
Figure 50. Display connection example with DSI.	74
Figure 51. DSI interface PCB track example for 0.8 mm ball pitch package	75

1 General information

This document applies to Arm^{®(a)}-based devices.



2 Reference documents

The following documents are available on www.st.com.

Table 1. Reference documents

Reference	Title
AN2867	Oscillator design guide for ST microcontrollers
AN1709	EMC design guide for ST microcontrollers
AN5275	USB DFU/USART protocols used in STM32MP1 Series bootloaders
AN5168	DDR configuration on STM32MP1 Series MPUs
AN5089	STM32MP1 Series and STPMIC1 hardware / software integration
AN5122	STM32MP1 Series DDR memory routing guidelines
AN5256	STM32MP151, STM32MP153 and STM32MP157 discrete power supply hardware integration
UM2535	Evaluation boards with STM32MP157 MPUs
UM2534	Discovery kits with STM32MP157 MPUs
RM0441	STM32MP151 advanced Arm [®] -based 32-bit MPUs
RM0442	STM32MP153 advanced Arm [®] -based 32-bit MPUs
RM0436	STM32MP157 advanced Arm [®] -based 32-bit MPUs
DS12500	STM32MP151A/D datasheet
DS12501	STM32MP151C/F datasheet
DS12502	STM32MP153A/D datasheet
DS12503	STM32MP153C/F datasheet
DS12504	STM32MP157A/D datasheet
DS12505	STM32MP157C/F datasheet

a. Arm is a registered trademark of Arm Limited (or its subsidiaries) in the US and/or elsewhere.

3 Glossary

Table 2. Glossary

Term	Meaning
ADC	Analog to digital converter
AHB	Advanced high-performance bus
CSI	Low power internal oscillator
CTI	Cross-trigger interface
DAC	Digital to analog converter
DAP	Debug access port
DDRCTRL	Double data rate SDRAM controller. Supports LPDDR2 and DDR3/DDR3L protocols
DDRPHYC	DDR physical interface control
DSI	Display serial interface master
ETH	Ethernet controller
EXTI	Extended interrupt and event controller
FMC	Flexible memory controller
GPIO	General purpose input output
HDP	Hardware debug port
HSE	High-speed external quartz oscillator
HSI	High-speed internal oscillator
I2C	Inter IC bus
IWDG	Independent watchdog
JTAG	Joint test action group. A debug interface
LSE	Low-speed external quartz oscillator
LSI	Low-speed internal oscillator
MDIOS	Management data input/output slave. Interface used to control Ethernet physical Interface
OTG	USB on the Go. An USB standard for interface able to become host or device
OTP	One time program memory
PMIC	Power management integrated circuit. External circuit which provides various platform power supplies with large controllability through signals and serial interface
PWR	Power control
QUADSPI	Quad data lanes serial peripheral interface
RCC	Reset and clock control
ROM	Read-only memory
RTC	Real time clock

Table 2. Glossary (continued)

Term	Meaning
SDMMC	Secure digital and multiMedia card interface. Supports SD, MMC, eMMC and SDIO protocols
SMPS	Switched mode power supply
SPI	Serial peripheral interface
STM	System trace macrocell
SW	Software
SWD	Serial wire debug
SWO	Single wire output. A trace port
SYSCFG	System configuration
TAMP	Tamper detection IP
TEMP	Temperature sensor
UART	Universal asynchronous receiver/transmitter
USART	Universal synchronous/asynchronous receiver/transmitter
USB	Universal serial bus
USBH	USB host controller
VREFBUF	ADC/DAC voltage reference buffer

4 Power supplies

Figure 1. Power supply scheme

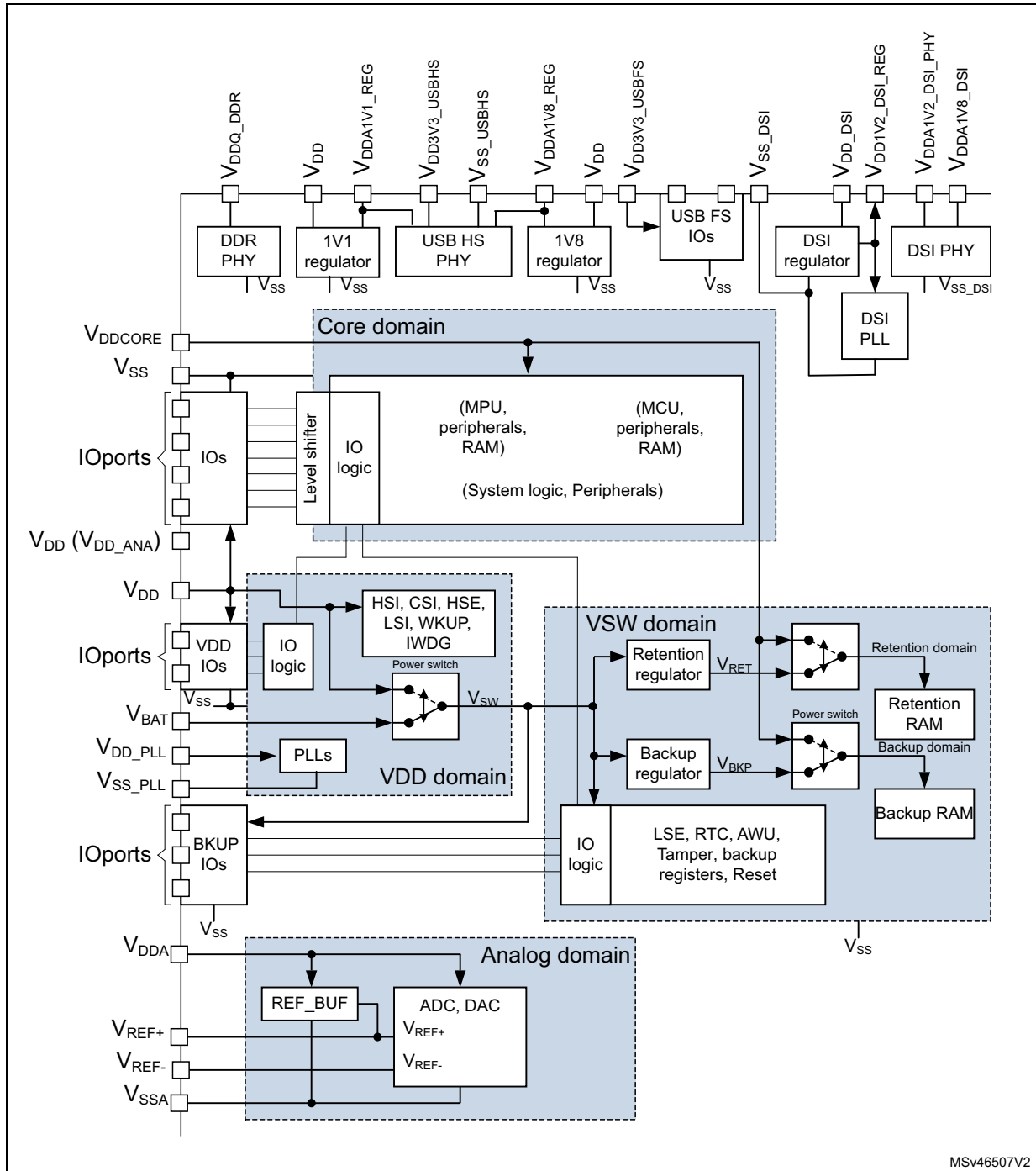

4.1 Introduction

Note: See details and guaranteed operating points in product datasheets.

- The main IOs voltage supply (V_{DD}) range is 1.71 V to 3.6 V.
- The core logic operating voltage supply (V_{DDCORE}) range is 1.18 V to 1.25 V.
- The USB supplies (V_{DD3V3_USBHS} and V_{DD3V3_USBFS}) range is 3.07 V to 3.6 V.
- Embedded regulators are used to supply some internal blocks.
 - 1.2 V LDO for DSI available on $V_{DD1V2_DSI_REG}$ which is used to supply DSI PLL and $V_{DD1V2_DSI_PHY}$ pin. Range is 1.15 V to 1.26 V.
 - 1.8 V LDO for DSI and USB available on V_{DDA1V8_REG} which is used to supply USB internally and V_{DDA1V8_DSI} .
When $BYPASS_REG1V8 = V_{DD}$, V_{DDA1V8_REG} must be supplied externally. In that case, range is 1.65 V to 1.95 V.
 - 1.1 V LDO for USB available on V_{DD1V1_REG} for external decoupling

Note: Embedded regulators must not be used to supply external components.

- The real-time clock (RTC) and backup registers can be powered from the V_{BAT} voltage when the main V_{DD} supply is powered off. This internal supply with automatic switch between V_{BAT} and V_{DD} is named V_{SW} domain and is also used to supply PI8, PC13, PC14, PC15 pads.

V_{BAT} voltage range is 1.20 V to 3.6 V.

When V_{DD} is above V_{BAT} , a small charging current could be enabled on V_{BAT} for an external backup voltage device (for example a supercapacitor).

4.1.1 Independent ADC and DAC converter supply and reference voltage

To improve the conversion accuracy and dynamic range, the ADC, DAC and reference have an independent power supply that can be filtered separately, and shielded from noise on the PCB.

The analog operating voltage supply (V_{DDA}) range is 1.71 V to 3.6 V (DAC could only be used when V_{DDA} is above or equal 1.8 V).

- The ADC/DAC/VREFBUF voltage supply input is available on a separate V_{DDA} pin.
- An isolated supply ground connection is provided on the V_{SSA} pin.
In all cases, the V_{SSA} pin should be externally connected to same supply ground than V_{SS} .

External VREF

The user can connect a separate external reference voltage ADC/DAC input on V_{REF+} . The voltage on V_{REF+} may range from 1.62 V to V_{DDA} .

Note: In order to work, DAC requires V_{REF+} above 1.8 V.

Internal VREF

The user can enable in the VREFBUF block an internal reference voltage on V_{REF+} . The voltage on V_{REF+} could be selected between 1.5 V, 1.8 V, 2.048 V and 2.5 V.

With internal VREF available on V_{REF+} pin, it could be used externally (for example for analog comparator reference) if loading is kept within datasheet values.

Note: In order to work, the DAC requires V_{REF+} above 1.8 V.

Note: The VREFBUF requires V_{DDA} equal to or higher than $V_{REF+} + 0.3$ V.

Caution: When available (depending on package), V_{REF-} must be externally tied to V_{SSA} .

Booster for ADC analog input switches

The ADC inputs are multiplexed with analog switches which have reduced performances when V_{DDA} supply is below 2.7 V. In order to get maximum ADC analog performances, it is alternatively possible to supply analog switches with either V_{DD} (if above 2.7 V) or an embedded 3.3 V booster from V_{DDA} .

The control is done in the SYSCFG_PMCR register.

Table 3. Recommended settings for ANASWVDD and EN_BOOSTER

V_{DDA} (V)	V_{DD} (V)	-->	SYSCFG_PMCR. ANASWVDD	SYSCFG_PMCR. EN_BOOSTER	Switches supply	ADC analog performances
>2.7	1.71 to 3.6	-	0	0	V_{DDA} (>2.7 V)	Maximum
<2.7	>2.7	-	1	0	V_{DD} (>2.7 V)	
	<2.7	-	0	1 ⁽¹⁾	Booster (~3.3 V)	
				0 ⁽²⁾	V_{DDA} (<2.7 V)	Reduced

1. Booster voltage can take up to 50 μ s to stabilize.

2. If reduced ADC analog performance is acceptable, the booster disabled could save up to 250 μ A.

4.1.2 Battery backup

To retain the content of the backup registers, BKPSRAM and RETRAM, when V_{DD} is turned off, the V_{BAT} pin can be connected to an optional standby voltage supplied by a battery or another source.

The V_{BAT} pin also powers the RTC unit, allowing the RTC to operate even when the main digital supply (V_{DD}) is turned off. The switch to the V_{BAT} supply is controlled by the power down reset (PDR) circuitry embedded in the reset block.

If no external battery is used in the application, it is required to connect V_{BAT} externally to V_{DD} .

4.1.3 Voltage regulators

The 1.8 V LDO (for USB and DSI) is always enabled after power on reset if $BYPASS_REG1V8 = V_{SS}$. It is not affected by (LP/LPLV-)Stop, but disabled on Standby entry.

The 1.1 V LDO (for USB) is always enabled after power on reset. It is not affected by (LP/LPLV-)Stop, but disabled on Standby entry.

The 1.2 V LDO (for DSI) is disabled after system reset and must be enabled by software before DSI is used. It is not affected by (LP/LPLV-)Stop, but disabled on Standby entry.

Note: The embedded regulators must not be used to supply external components unless specifically mentioned.

4.2 Power supply schemes

The circuit is powered by multiple power supplies:

- The V_{DD} is the main supply for IOs and internal part kept powered during the Standby mode. The useful voltage range is 1.71 V to 3.6 V (for example: 1.8 V, 2.5 V, 3.0 V or 3.3 V typ.)
 - Those supplies must be connected to external decoupling capacitors (see [Table 4](#)).
 - V_{DD_DSI} , V_{DD_PLL} and V_{DD_ANA} must be connected to V_{DD}
- The V_{DDCORE} is the main digital voltage and could be shutdown externally during the Standby mode. The voltage range during Run mode is 1.18 V to 1.25/1.38 V (1.2/1.34 V typ.).
 - This supply must be connected to external decoupling capacitors (see [Table 4](#))
 - V_{DDCORE} could be reduced further in specific Stop mode (LPLV_Stop). This involves either PWR_ON signal (for example with STPMIC1, external power management IC) or PWR_LP signal (with discrete SMPS components)
- The V_{BAT} pin can be connected to the external battery ($1.2\text{ V} < V_{BAT} < 3.6\text{ V}$).
 - If RETRAM is used, minimum V_{BAT} is 1.4 V
 - If application does not support backup battery, it is recommended to connect this pin to V_{DD} .
 - If application is supporting backup battery, it is recommended to add a 100 nF ceramic decoupling capacitor between V_{BAT} and V_{SS} .
 - If application is using a supercapacitor on V_{BAT} , no additional decoupling is required.
- The V_{DDA} pin is the analog (ADC/DAC/VREFBUF) supply and must be connected to external decoupling capacitors (see [Table 4](#)).
- The V_{REF+} pin can be connected to the V_{DDA} external power supply. If a separate, internal or external, reference voltage is applied on V_{REF+} , a decoupling capacitor must be connected between this pin and V_{REF-} . (see [Table 4](#)). Refer to [Section 4.1.1](#).
Additional precautions can be taken to filter analog noise:
 - V_{DDA} can be connected to V_{DD} through an inductor based filter.
- V_{DDQ_DDR} is the DDR IO supply and must be connected to external decoupling capacitors (see [Table 4](#)).
 - Voltage range is 1.425 V to 1.575 V for interfacing DDR3 memories (1.5 V typ.)
 - Voltage range is 1.283 V to 1.45 V for interfacing DDR3L memories (1.35 V typ.)
 - Voltage range is 1.14 V to 1.3 V for interfacing LPDDR2 or LPDDR3 memories (1.2 V typ.)
- $V_{DDA1V2_DSI_REG}$ pin is the output of internal regulator and must be connected to external decoupling capacitors (see [Table 4](#)).
 - $V_{DDA1V2_DSI_REG}$ is connected internally to DSI PLL.
- $V_{DDA1V2_DSI_PHY}$ is the analog DSI PHY supply. Voltage range is 1.15 V to 1.26 V. (1.2 V typ.)
 $V_{DDA1V2_DSI_PHY}$ should be connected to $V_{DDA1V2_DSI_REG}$.

- V_{DD3V3_USBHS} and V_{DD3V3_USBFS} are respectively the USB high-speed and full-speed PHY supply. Voltage range is 3.07 V to 3.6 V. Must be connected together to external decoupling capacitors (see [Table 4](#)).
 V_{DD3V3_USBFS} is used to supply OTG_VBUS and OTG_ID (PA10) pins. So, V_{DD3V3_USBFS} must be supplied as well when USB high-speed dual-role-port or USB high-speed device is used. If not used, should be connected to V_{DD} .
- The V_{DDA1V8_REG} pin is the output of internal regulator and must be connected to external decoupling capacitors (see [Table 4](#)).
 - V_{DDA1V8_REG} , is connected internally to USB PHY and USB PLL.
 - Internal V_{DDA1V8_REG} regulator is enabled by default and could be controlled by software. It is always shutdown during Standby.

For the 1.8 V voltage regulator configuration, there is specific $BYPASS_REG1V8$ pin that should be connected either to V_{SS} or V_{DD} to activate or deactivate the voltage regulator. It is mandatory to bypass the 1.8 V regulator when V_{DD} is below 2.25 V:

 - $BYPASS_REG1V8 = V_{DD}$. In that case, V_{DDA1V8_REG} pin should be connected to V_{DD} (if below 1.98V) or a dedicated 1.65 V - 1.98 V supply (1.8 V typ.).
 - $BYPASS_REG1V8 = V_{SS}$. In that case, V_{DD} must be above 2.25 V to allow correct behavior of 1.8 V voltage regulator.
 - Refer to [Section 4.1.3](#) and section "Embedded regulators characteristics" of the related device datasheet for details.
- V_{DDA1V8_DSI} is the analog DSI supply. the voltage range is 1.65 V to 1.98 V. (1.8 V typ.) Should be connected to V_{DDA1V8_REG} and must be connected to external decoupling capacitors (see [Table 4](#)).
- V_{DDA1V1_REG} pin is the output of internal regulator and must be connected to external decoupling capacitors (see [Table 4](#)). The voltage range is 1.045 V to 1.155 V (1.1 V typ.)
 - V_{DDA1V1_REG} is connected internally to USB PHY.
 - Internal V_{DDA1V1_REG} regulator is enabled by default and could be controlled by software. It is always shutdown during Standby.

Caution: V_{DD3V3_USBHS} must not be present unless V_{DDA1V8_REG} is present, otherwise permanent STM32MP15x lines damage could occur. Must be ensured by PMIC ranking order or with external component in case of discrete component power supply implementation.

Caution: All supply grounds (V_{SS} , V_{SS_ANA} , V_{SS_PLL} , V_{SS_USBHS} , V_{SS_DSI} , V_{SSA} and V_{REF} .) should be connected together with power planes.

Table 4. Amount of decoupling recommendation by package⁽¹⁾

Supplies pins	Decoupling point ⁽²⁾	Value	LFPGA354	TFPGA257	TFPGA361	LFPGA448	Comments
V _{BAT}	V _{SS}	100 nF	1	1	1	1	could be skipped if V _{BAT} is connected to V _{DD} or if a supercapacitor is used instead of a battery
V _{DDCORE}	V _{SS}	1 μF ⁽³⁾	15	15	15	15	Not including capacitors on PMIC/SMPS
V _{DDQ_DDR}	V _{SS}	1 nF	2	2	2	2	Not including capacitors on PMIC/SMPS and additional capacitors on DDR memory
		3.3 nF	0	3	0	0	
		1 μF ⁽³⁾	4	2	7	7	
V _{DD_ANA}	V _{SS_ANA}	1 μF ⁽³⁾	1	-(4)	1	1	-
V _{DD_PLL} , V _{DD_PLL2}	V _{SS_PLL} , V _{SS_PLL2}	1 μF ⁽³⁾	2	-(4)	-(4)	2	Not including capacitors on PMIC/SMPS.
V _{DD} , V _{DD_DSI}	V _{SS}	1 μF ⁽³⁾	4	4	4	4	
V _{DD1V2_DSI_REG} , V _{DD1V2_DSI_PHY}	V _{SS_DSI}	2.2 μF ⁽³⁾	1	-	1	1	-
	V _{SS}		-	1 ⁽⁵⁾	-	-	
V _{DDA1V8_REG}	V _{SS_USBHS}	2.2 μF ⁽³⁾	1	-	1	1	-
	V _{SS}		-	1 ⁽⁵⁾	-	-	
V _{DDA1V8_DSI}	V _{SS_DSI}	1 μF ⁽³⁾	1	-	1	1	V _{DDA1V8_DSI} must be connected to V _{DDA1V8_REG}
	V _{SS}		-	1 ⁽⁵⁾	-	-	
V _{DDA1V1_REG}	V _{SS_USBHS}	2.2 μF ⁽³⁾	1	-	1	1	-
	V _{SS}		-	1 ⁽⁵⁾	-	-	
V _{DD3V3_USBHS} , V _{DD3V3_USBFS}	V _{SS_USBHS}	1 μF ⁽³⁾	1	-	1	1	-
	V _{SS}		-	1 ⁽⁵⁾	-	-	
V _{DD3V3_USB}	V _{SS}		-	1 ⁽⁵⁾	-	-	
V _{DDA}	V _{SSA}	100 nF + 1 μF ⁽³⁾	1+1	1+1	1+1	1+1	V _{SSA} must be connected to V _{SS} plane
V _{REF+}	V _{REF-} and V _{SSA}	100 nF + 1 μF ⁽³⁾	1+1	-	-	1+1	V _{REF-} must be connected to V _{SSA} then V _{SS} plane
	V _{SSA}		-	1+1 ⁽⁶⁾	1+1 ⁽⁶⁾	-	V _{SSA} must be connected to V _{SS} plane

1. This table could be used as a guideline, the real count and values of capacitors could be adapted depending of various parameters: capacitor size, capacitor dielectric, PCB technology, and using results of product power integrity simulations.
2. All V_{SS_x} and V_{SSA} must be connected to a common V_{SS} plane.
3. Multi Layer Ceramic Capacitor type (MLCC).
4. Supply internally merged with V_{DD}.
5. Supply return path internally merged with V_{SS}.
6. V_{REF-} internally merged with V_{SSA}.

4.3 Reset and power supply supervisor

4.3.1 Power on reset (POR) / power down reset (PDR)

The device has an integrated POR/PDR circuitry that allows proper operation starting from 1.71 V.

The device remains in the reset mode as long as V_{DD} is below a specified threshold, $V_{POR/PDR}$, without the need for an external reset circuit. For more details concerning the power on/power down reset threshold, refer to the electrical characteristics in the product datasheets.

Figure 2. Power-on reset/power-down reset waveform

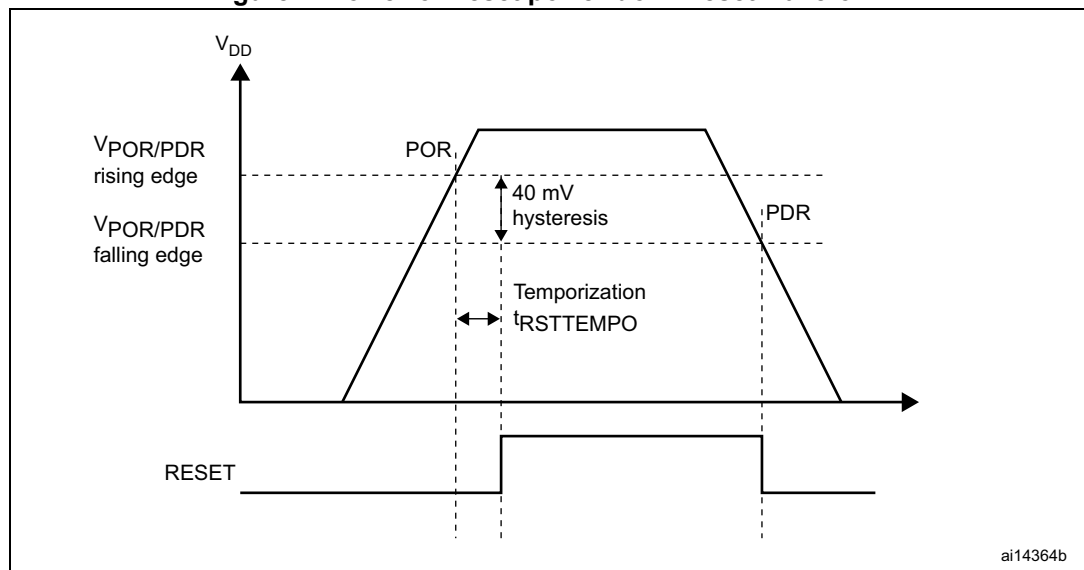

1. $t_{RSTTEMPO}$ is approximately 2.6 ms. $V_{POR/PDR}$ rising edge is 1.67 V (typ.) and $V_{POR/PDR}$ falling edge is 1.63 V (typ.). Refer to STM32MP15x datasheets for actual value.

The internal power-on reset (POR) / power-down reset (PDR) circuitry can be disabled through the PDR_ON pin. In that case, an external power supply supervisor should monitor V_{DD} and should maintain the device in reset mode as long as V_{DD} is below a specified threshold.

4.3.2 Programmable voltage detector (PVD)

The user can use the PVD to monitor the V_{DD} power supply by comparing it to a threshold selected by the PLS[2:0] bits in the power control register (PWR_CR).

The PVD is enabled by setting the PVDE bit.

A PVDO flag is available, in the power control/status register (PWR_CSR), to indicate whether V_{DD} is higher or lower than the PVD threshold. This event is internally connected to EXTI Line16 and can generate an interrupt if enabled through the EXTI registers. The PVD output interrupt can be generated when V_{DD} drops below the PVD threshold and/or when V_{DD} rises above the PVD threshold depending on the EXTI Line16 rising/falling edge configuration. As an example the service routine can perform emergency shutdown tasks.

Figure 3. PVD thresholds

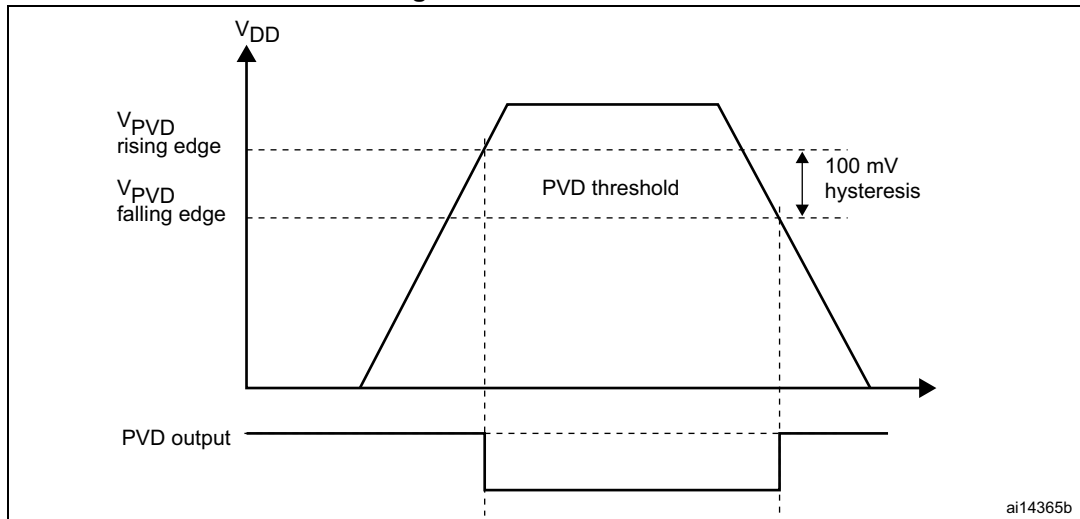

4.3.3 Application and system resets

An application reset (`app_rst`) is generated from one of the following sources:

- A reset from NRST pad,
- A reset from `por_rst` signal (generally called power-on reset),
- A reset from `bor_rst` signal (generally called brownout),
- A reset from the Independent Watchdogs 1 (`iwdg1_rst`),
- A reset from the Independent Watchdogs 2 (`iwdg2_rst`),
- A software reset from the Cortex-M4 (MCU), via the AIRCR register (`MCSYSRST`) if the option byte `OPT_MCU_SYSRST_EN` allows it,
- A software reset from the RCC, when the Cortex-A7 (MPU) sets the bit `MPSYSRST` to '1' in the RCC,
- A failure on HSE, when the clock security system feature is activated (`hcss_rst`).

A System reset (`nreset`) is generated from one of the following sources:

- A reset from `app_rst` signal (application reset),
- A reset from `vcore_rst` signal.

Note: When the system is in Standby, the V_{DDCORE} is switched off, but V_{DD} is still present. So when the system exits from Standby, the `vcore_rst` signal is activated, generating a `nreset` reset.

Note: It is required to connect NRST to NRST_CORE, using a capacitor of 1/10th the capacitor put on NRST, when there is no V_{DDCORE} power cycle on NRST activation (done by default with `STPMIC1`). Refer to product errata sheet for details.

Refer to RCC section in the reference manual for more details on reset coverage.

Figure 4. Simplified reset pin circuit

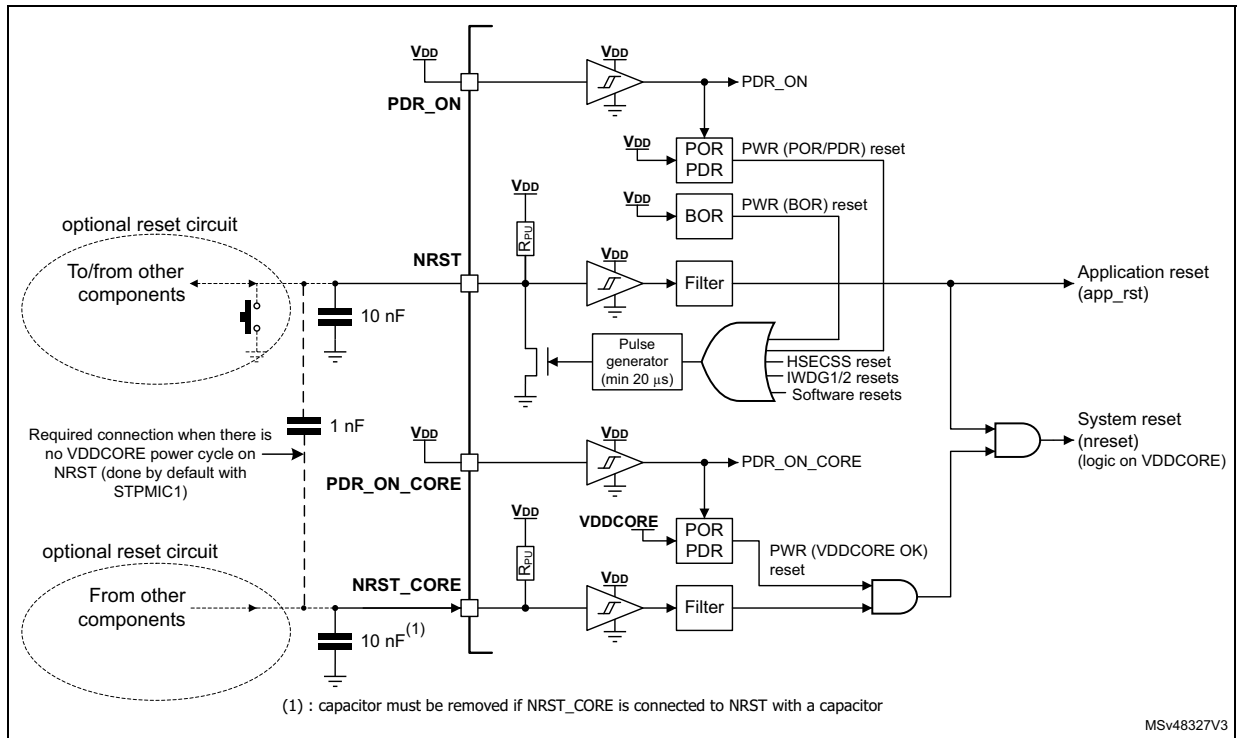

5 Packages

5.1 Package selection

The package must be selected by taking into account the constraints that are strongly dependent upon the application.

The list below summarizes the more frequent constraints:

- Amount of interfaces required.
Some interfaces might not be available on some packages.
Some interfaces combinations might not be possible on some packages.
Refer to product datasheets for details
- PCB technology constraints.
Small pitch and high ball density could require more PCB layers and higher PCB class requiring stackup with micro-via (laser via) technology
- Package height
- PCB available area
- Thermal constraints (larger packages have better thermal dissipation capabilities)

Table 5. Package summary

Size (mm) ⁽¹⁾	16 x 16	10 x 10	12 x 12	18 x 18
Minimum Pitch (mm)	0.8	0.5	0.5	0.8
Height (mm)	1.4	1.2	1.2	1.4
Sales numbers	LFBGA354	TFBGA257	TFBGA361	LFBGA448
STM32MP151xxx	X	X	X	X
STM32MP153xxx	X	X	X	X
STM32MP157xxx	X	X	X	X

1. Typical body size.

Table 6. Major feature changes related to packages

Packages		TFBGA257	LFBGA354	TFBGA361	LFBGA448
Package	Body Size (mm)	10x10	16x16	12x12	18x18
	Pitch (mm)	0.5 (center 0.65)	0.8	0.5 (center 0.65)	0.8
	Thickness (mm)	<1.2	<1.4	<1.2	<1.4
	Ball count	257	354	361	448
SDRAM	LPDDR2/3	16-bits 533 MHz	Up to 1 GByte, single rank		
		32-bits 533 MHz	-	Up to 1GByte, single rank	
	DDR3/3L	16-bits 533 MHz	Up to 1 GByte, single rank		
		32-bits 533 MHz	-	Up to 1GByte, single rank	
FMC	Parallel Address/Data 8/16 bits	-	4 × CS, up to 4 × 64 MBytes		
	Parallel AD-Mux 8/16 bits	4 × CS, up to 4 × 64 MBytes			
	NAND 8/16 bits	Yes, 2 × CS, SLC, BCH4/8			
Gigabit Ethernet		-	MII, RMII, GMII, RGMII with PTP and EEE		
10/100M Ethernet		MII, RMII with PTP and EEE			
GPIOs with interrupt (total count)		98	148	176	
-	Securable GPIOs	-	8		
	Wakeup pins	4	6		
	Tamper pins (active tamper)	2 (1)	3 (1)		
Up to 16 bit synchronized ADC		2 (up to 0.25/4.4/5/5.7/6.7 Msps on 16/14/12/10/8 bits each)			
-	Low noise 16 bit (differential)	-	2 (1)		
	16 bit (differential)	17 (7)	20 (9)		
	ADC channels in total	17	22		

5.2 Alternate function mapping to pins

In order to easily explore peripheral alternate functions mapping to pins, it is recommended to use the STM32CubeMX tool available on www.st.com.

Figure 5. STM32CubeMX example screen-shot

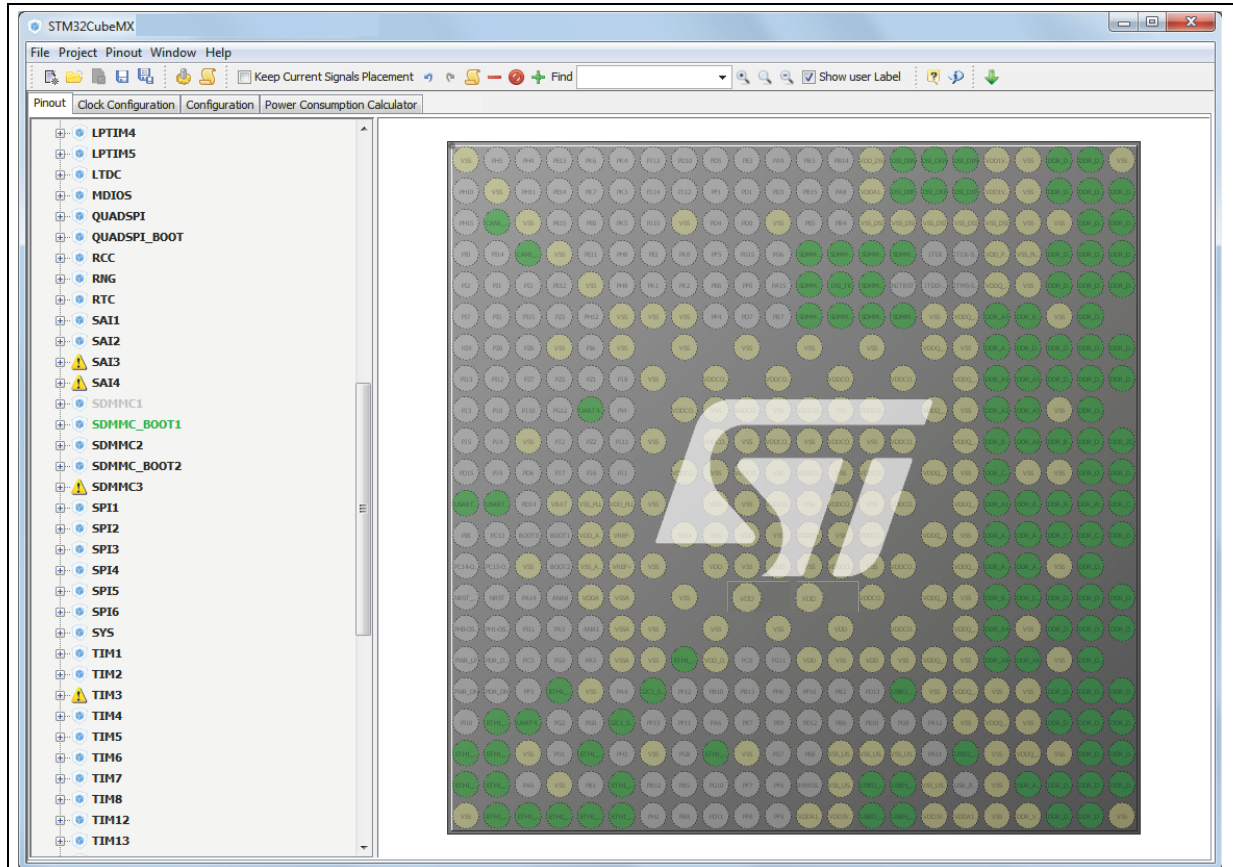

5.3 Package compatibility between versions

The STM32MP151xxx, STM32MP153xxx devices slightly differ from the STM32MP157xxx devices. Nevertheless, it is possible to build a compatible PCB at the expense of few additional connections.

Table 7. Device compatibility summary

PCB made for	Device used		
	STM32MP151xxx	STM32MP153xxx	STM32MP157xxx
STM32MP151xxx	Compatible	Compatible	Compatibility possible (See Table 8 to Table 11 and Figure 6 to Figure 9)
STM32MP153xxx	Compatible	Compatible	
STM32MP157xxx	Compatible	Compatible	Compatible

Table 8. STM32MP151xxx and STM32MP153xxx for 16x16 LFBGA354 compatibility

Ball connection to add	STM32MP151xxx	STM32MP153xxx	STM32MP157xxx
B12 to V11 (VDD1V8_REG)	VDDA1V8_Unused		VDDA1V8_DSI
A16 to B16 + 1 μ F to VSS	VDD1V2_Unused		VDD1V2_DSI_PHY / VDD1V2_DSI_REG
A12 to VDD	VDD_Unused		VDD_DSI

Figure 6. 16x16 LFBGA354 compatibility

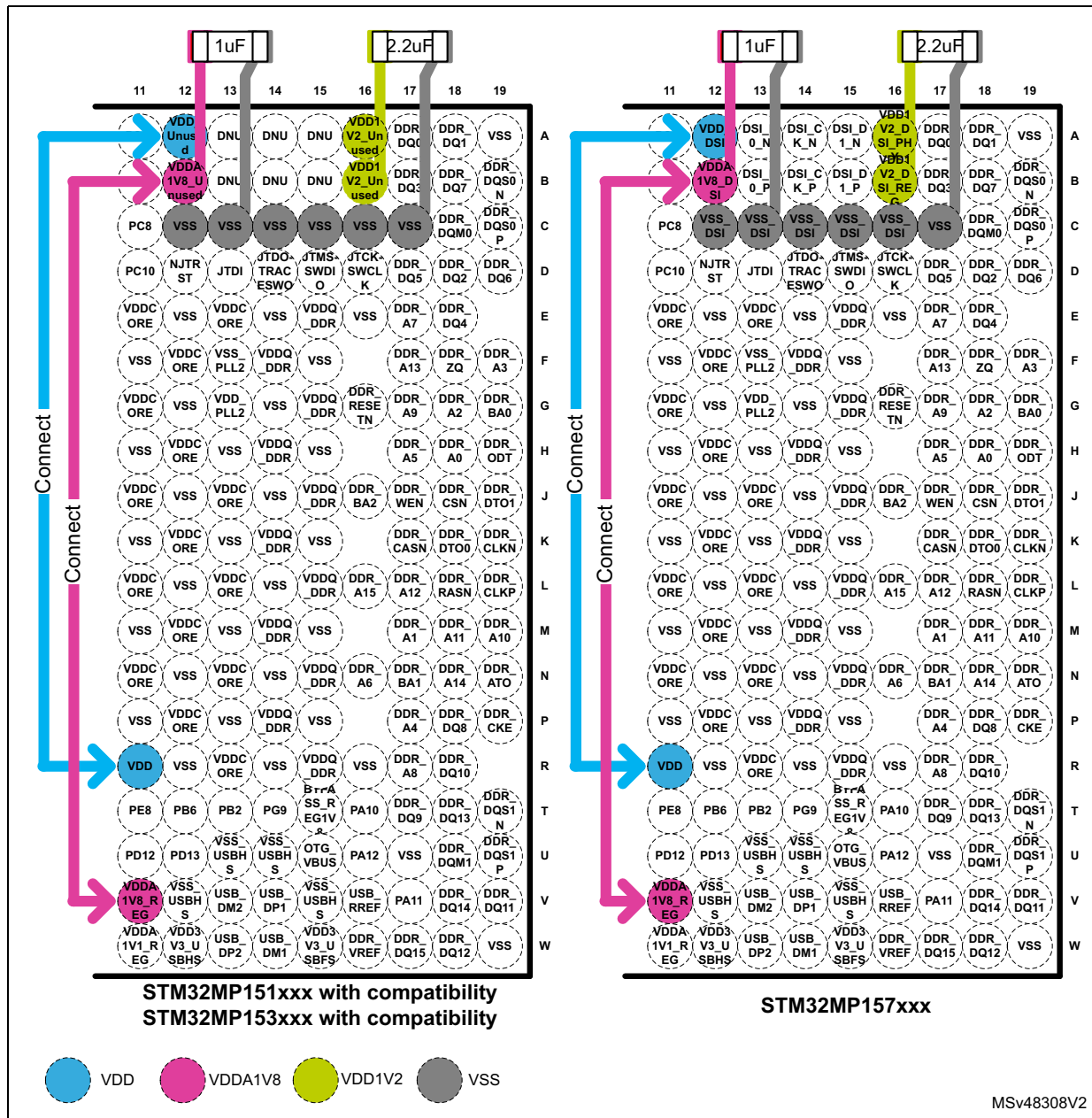

Note: This drawing is to help understanding and does not show realistic board traces and components size/placement.

Table 9. STM32MP151xxx and STM32MP153xxx for 10x10 TFBGA257 compatibility

Ball connection to add	STM32MP151xxx	STM32MP153xxx	STM32MP157xxx
1B6 to 1H5 (VDD1V8_REG)	VDDA1V8_Unused		VDDA1V8_DSI
1B7 to 1A7 + 1 μ F to VSS	VDD1V2_Unused		VDD1V2_DSI_PHY / VDD1V2_DSI_REG
C13 to VDD	VDD_Unused		VDD_DSI

Figure 7. 10x10 TFBGA257 compatibility

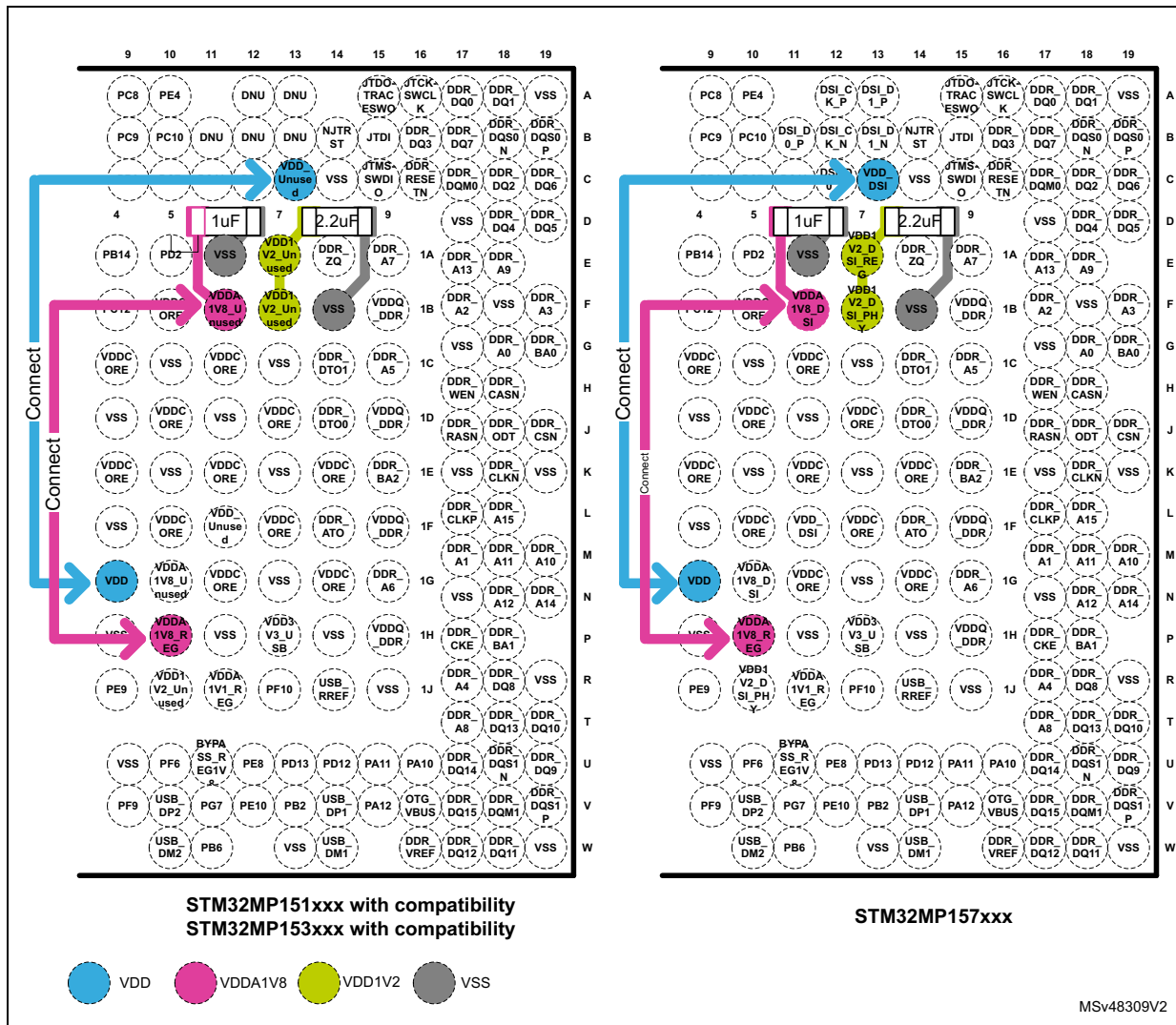

Note: This drawing is to help understanding and does not show realistic board traces and components size/placement.

Table 10. STM32MP151xxx and STM32MP153xxx for 12x12 TFBGA361 compatibility

Ball connection to add	STM32MP151xxx	STM32MP153xxx	STM32MP157xxx
C14 to AB14 (VDD1V8_REG)	VDDA1V8_Unused		VDDA1V8_DSI
C17 to C18 + 1 µF to VSS	VDD1V2_Unused		VDD1V2_DSI_PHY / VDD1V2_DSI_REG
B18 to VDD	VDD_Unused		VDD_DSI

Figure 8. 12x12 TFBGA361 compatibility

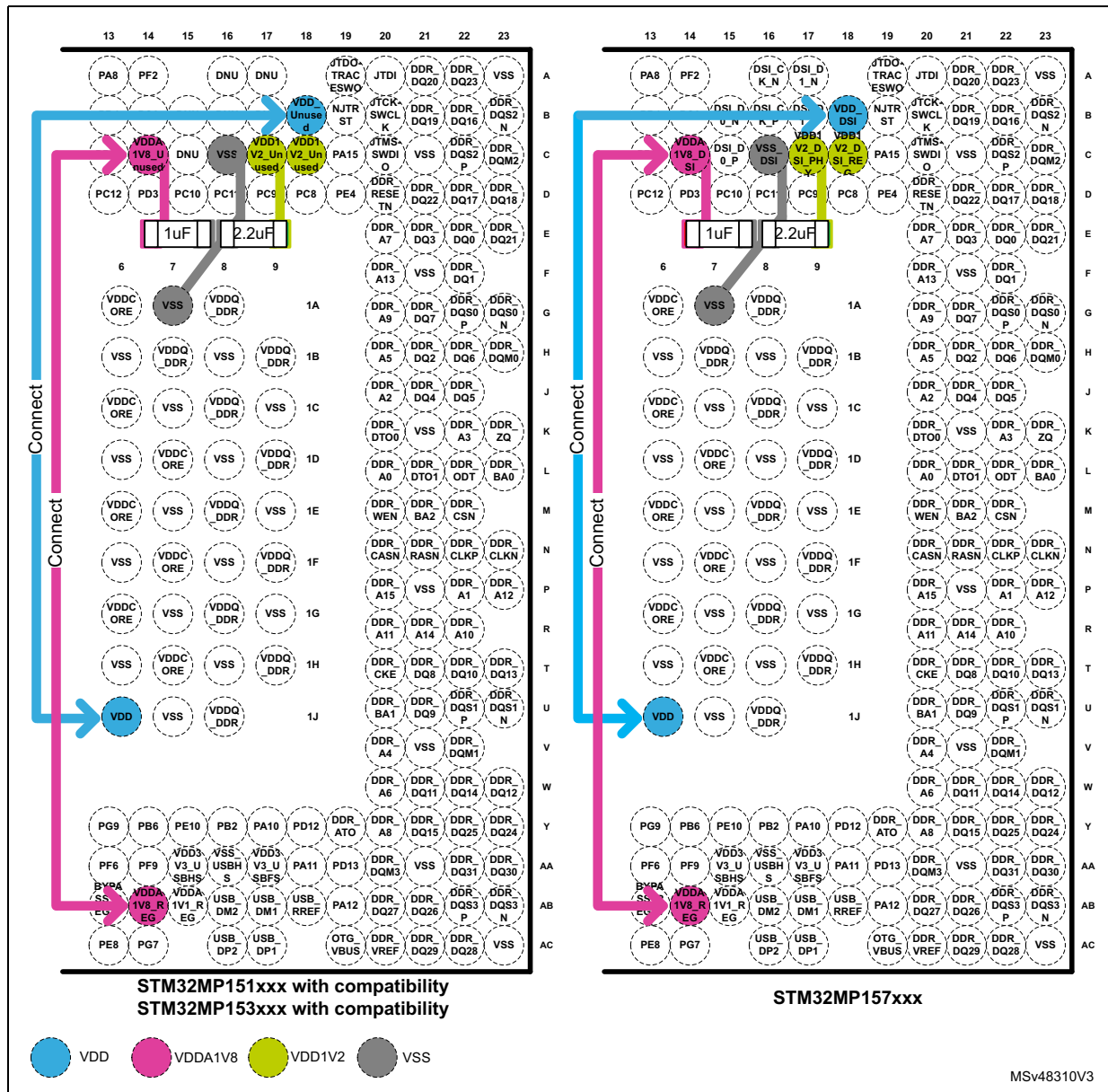

Note: This drawing is to help understanding and does not show realistic board traces and components size/placement.

Table 11. STM32MP151xxx and STM32MP153xxx for 18x18 LFBGA448 compatibility

Ball connection to add	STM32MP151xxx	STM32MP153xxx	STM32MP157xxx
B14 to AB12 (VDD1V8_REG)	VDDA1V8_Unused		VDDA1V8_DSI
A18 to B18 + 1 μF to VSS	VDD1V2_Unused		VDD1V2_DSI_PHY / VDD1V2_DSI_REG
A14 to VDD	VDD_Unused		VDD_DSI

Figure 9. 18x18 LFBGA448 compatibility

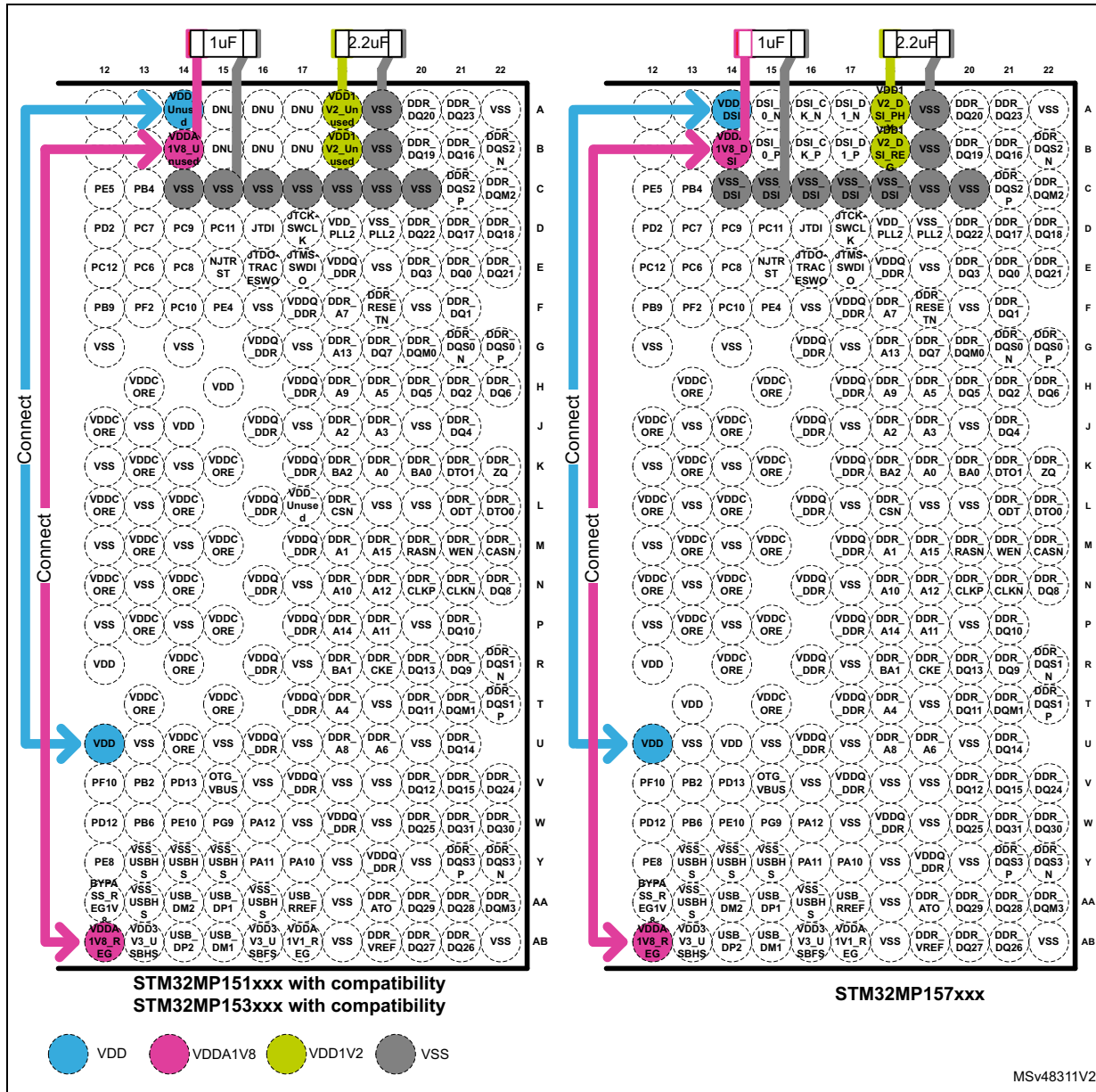

Note: This drawing is to help understanding and does not show realistic board traces and components size/placement.

6 Clocks

Different clock sources can be used to drive the sub-systems clocks:

- HSI oscillator clock (high-speed internal clock signal)
- CSI oscillator clock (low power internal clock signal)
- HSE oscillator clock (high-speed external clock signal)
- PLL1/2/3/4 clocks
- PLL_DSI to generate the DSI clock (up to 1 GHz)^(a)
- PLL_USB to generate the USB clock (480 MHz)

The devices have two secondary clock sources:

- 32 kHz low-speed internal RC (LSI RC) that drives the independent watchdog and, optionally, the RTC used for auto-wakeup from the Stop/Standby modes.
- 32.768 kHz low-speed external crystal (LSE crystal) that optionally drives the real-time clock (RTCCLK)

Each clock source can be switched on or off independently when it is not used, to optimize the power consumption.

Refer to the RM0436, RM0441, RM0442 reference manuals for the description of the clock tree.

6.1 HSE OSC clock

The high-speed external clock signal (HSE) can be generated from two possible clock sources:

- HSE user external clock (see [Figure 10](#))
- HSE external crystal/ceramic resonator (see [Figure 11](#))

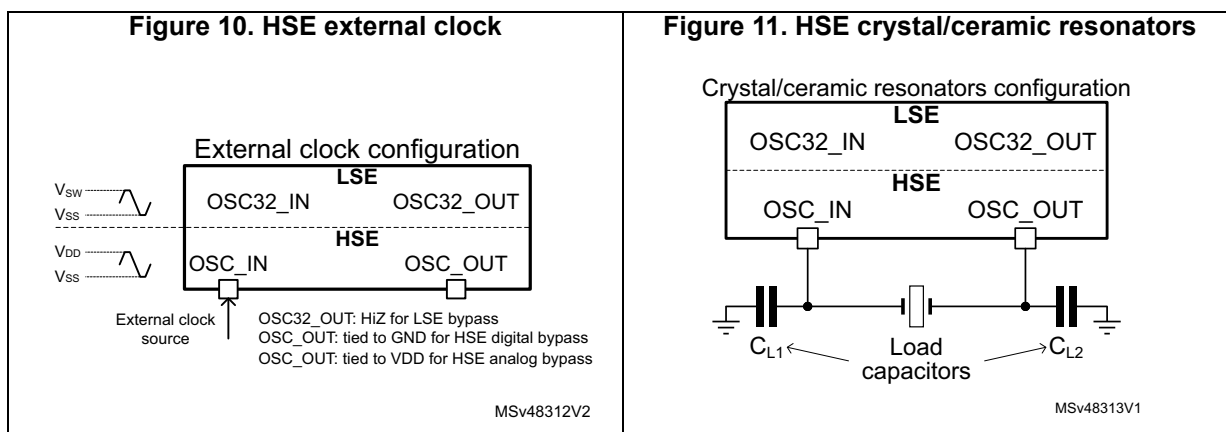

1. Refer *Oscillator design guide for ST microcontrollers* application note (AN2867).
2. Load capacitance C_L has the following formula: $C_L = C_{L1} \times C_{L2} / (C_{L1} + C_{L2}) + C_{stray}$ where: C_{stray} is the pin capacitance and board or trace PCB-related capacitance. Typically, it is between 2 pF and 4 pF. Refer to [Section 9: Recommendations on page 42](#) to minimize its value.

a. Availability depends on the STM32MP15x lines devices.

6.1.1 External source (HSE bypass)

In this mode, an external clock source must be provided. It can have a frequency from 8 to 50 MHz (refer to STM32MP15x datasheets for actual max value).

The external digital (V_{IL}/V_{IH}) or analog (amplitude of 200 mV pk-pk minimum) clock signal with a duty cycle of about 50%, has to drive the OSC_IN pin.

Note: In order to allow USB boot, the BootROM automatically selects the HSE mode by checking the OSC_OUT connection during startup phase (that is on NRST rising edge):

- OSC_OUT is tied to GND (max 1 Kohm): HSE digital bypass
- OSC_OUT is tied to VDD (max 1 Kohm): HSE analog bypass
- OSC_OUT high-impedance or connected to a crystal/ceramic resonator: HSE crystal/ceramic resonator mode.

When Bypass is used, the external clock generator could be enabled by PWR_ON to save power (that is disabled in Standby). In that case, the OSC_IN clock input should be stable within 10 ms after the PWR_ON rising edge occurs.

6.1.2 External crystal/ceramic resonator (HSE crystal)

The external oscillator frequency ranges from 8 to 48 MHz.

The external oscillator has the advantage of producing a very accurate rate on the main clock. The associated hardware configuration is shown in [Figure 11](#). Using a 24 MHz crystal frequency is a good choice to get accurate USB high-speed clocks.

The crystal/ceramic resonator and the load capacitors have to be connected as close as possible to the oscillator pins in order to minimize output distortion and startup stabilization time. The load capacitance values must be adjusted according to the selected crystal/ceramic resonator.

For C_{L1} and C_{L2} it is recommended to use NP0/C0G capacitors in the 5 pF-to-25 pF range (typ.), selected to meet the load requirements of the crystal/ceramic resonator. C_{L1} and C_{L2} , have usually the same value. The crystal manufacturer typically specifies a load capacitance that is the series combination of C_{L1} and C_{L2} . The PCB and pin capacitances must be included when sizing C_{L1} and C_{L2} (10 pF can be used as a rough estimate of the combined pin and board capacitance).

Refer to *oscillator design guide for ST microcontrollers* application note (AN2867) and electrical characteristics sections in the product datasheet for more details.

6.2 LSE OSC clock

The low-speed external clock signal (LSE) can be generated from two possible clock sources:

- LSE user external clock (see [Figure 12](#))
- LSE external crystal/ceramic resonator (see [Figure 13](#))

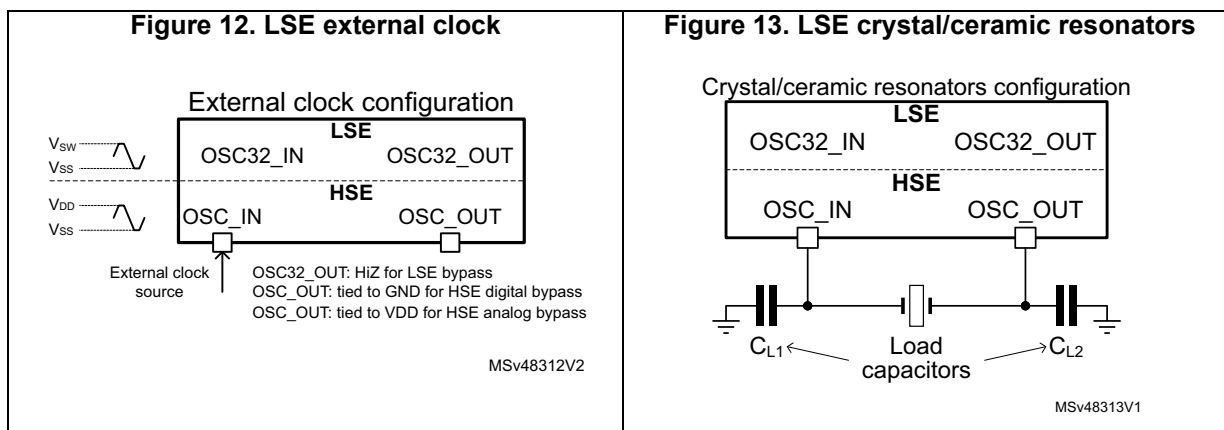

1. **“LSE crystal/ceramic resonators” figure:**
It is strongly recommended to use a resonator with a load capacitance $C_L \leq 12.5$ pF.
2. **“LSE external clock” and “LSE crystal/ceramic resonators” figures:**
OSC32_IN and OSC32_OUT pins can be used also as GPIO, but it is recommended not to use them as both RTC and GPIO pins in the same application.

6.2.1 External source (LSE bypass)

In this mode, an external clock source must be provided. It can have a frequency of up to 1 MHz. The external digital (VIL/VIH) or analog (amplitude of 200 mV pk-pk minimum) clock signal with a duty cycle of about 50% has to drive the OSC32_IN pin while the OSC32_OUT pin must be left high impedance (see [Figure 12](#)). The configuration of the bypass mode as well as the selection between the digital and analog is done within RCC registers

6.2.2 External crystal/ceramic resonator (LSE crystal)

The LSE crystal is a 32.768 kHz low-speed external crystal or ceramic resonator. It has the advantage of providing a low-power, but highly accurate clock source to the real-time clock peripheral (RTC) for clock/calendar or other timing functions.

The resonator and the load capacitors have to be connected as close as possible to the oscillator pins in order to minimize output distortion and startup stabilization time. The load capacitance values C_{L1} and C_{L2} must be adjusted according to the selected oscillator.

Refer to *Oscillator design guide for ST microcontrollers* dedicated application note (AN2867) and electrical characteristics sections in the product datasheet for more details.

6.3 Clock security system (CSS)

Details can be found in the product reference manual (See [Table 1: Reference documents](#)).

6.3.1 CSS on HSE

The clock security system can be activated by software. In this case, the clock detector is enabled after the HSE oscillator startup delay, and disabled when this oscillator is stopped.

- If a failure is detected on the HSE oscillator clock, a system reset can be generated as well as signaled to the TAMP block for security protection.

6.3.2 CSS on LSE

The clock security system can be activated by software. In this case, the clock detector is enabled after the LSE oscillator startup delay, and disabled when this oscillator is stopped.

- If a failure is detected on the LSE oscillator clock, the RTC/TAMP clock source is stopped as well as signaled to the TAMP block for security protection.

7 Boot configuration

7.1 Boot mode selection

In the STM32MP15x lines devices, different boot modes can be selected by means of the BOOT[2:0] pins. The reserved configuration is highlighted in gray in the table.

Table 12. Boot modes

BOOT2	BOOT1	BOOT0	Initial boot mode	Comments
0	0	0	UART and USB ⁽¹⁾	Wait incoming connection on: – USART2/3/6 and UART4/5/7/8 on default pins – USB High-Speed device on OTG_HS_DP/DM pins ⁽²⁾
0	0	1	Serial NOR-Flash ⁽³⁾	Serial NOR-Flash on QUADSPI ⁽⁵⁾
0	1	0	eMMC™ ⁽³⁾	eMMC™ on SDMMC2 (default) ⁽⁵⁾⁽⁶⁾
0	1	1	NAND-Flash ⁽³⁾	SLC NAND-Flash on FMC
1	0	0	Engineering boot (No Flash boot)	Used to get debug access without boot from Flash ⁽⁴⁾
1	0	1	SD-Card ⁽³⁾	SD-Card on SDMMC1 (default) ⁽⁵⁾⁽⁶⁾
1	1	0	UART and USB ⁽¹⁾⁽³⁾	Wait incoming connection on: – USART2/3/6 and UART4/5/7/8 on default pins – USB High-speed device on OTG_HS_DP/DM pins ⁽²⁾
1	1	1	Serial NAND-Flash ⁽³⁾	Serial NAND-Flash on QUADSPI ⁽⁵⁾

1. Could be disabled by OTP settings. Note that an HSE clock/crystal is always required even for UART boot, unless USB and HSE frequency auto-detection are disabled in OTP.
2. USB requires an HSE clock/crystal (see [Section 7.3: Embedded boot loader mode](#)).
3. Boot source could be changed by OTP settings (such as Initial boot on SD-Card, then eMMC with OTP settings).
4. Cortex-A7 Core0 in infinite loop toggling PA13, Cortex-M4 in infinite loop on RETRAM.
5. Default pins can be altered by OTP.
6. Alternatively, another SDMMC interface than this default can be selected by OTP.

The values on the BOOT pins are sampled by BootROM after a reset. It is up to the user to set the BOOT[2:0] pins before reset exit to select the required boot mode.

The BOOT pins could also be resampled later by software (for example by reading SYSCFG_BOOTR_BOOT[2:0] field) or by the BootROM when exiting the Standby mode. Consequently, they must be kept in the required boot mode configuration all the time.

During Stop modes, when the BOOT[2:0] pins are connected to V_{DD}, as the three embedded pull-down are enabled by default, some current is flowing thru the pull-down. In order to save some tens of μA of power, the software could disable the pull-down on pins which are connected to V_{DD} by simply setting field SYSCFG_BOOTR_BOOT[2:0]_PD equal to value read in SYSCFG_BOOTR_BOOT[2:0] field. This must be done again after each Standby exit as the SYSCFG_BOOTR register is reset. Note that during Standby, the BOOT[2:0] pins are set in tri-state and no current is flowing in BOOT[2:0] pins even if connected to V_{DD}.

7.2 Boot pin connection

Figure 14 shows an example of the external connection required to select the boot memory of the STM32MP15x lines devices.

Figure 14. Boot mode selection example

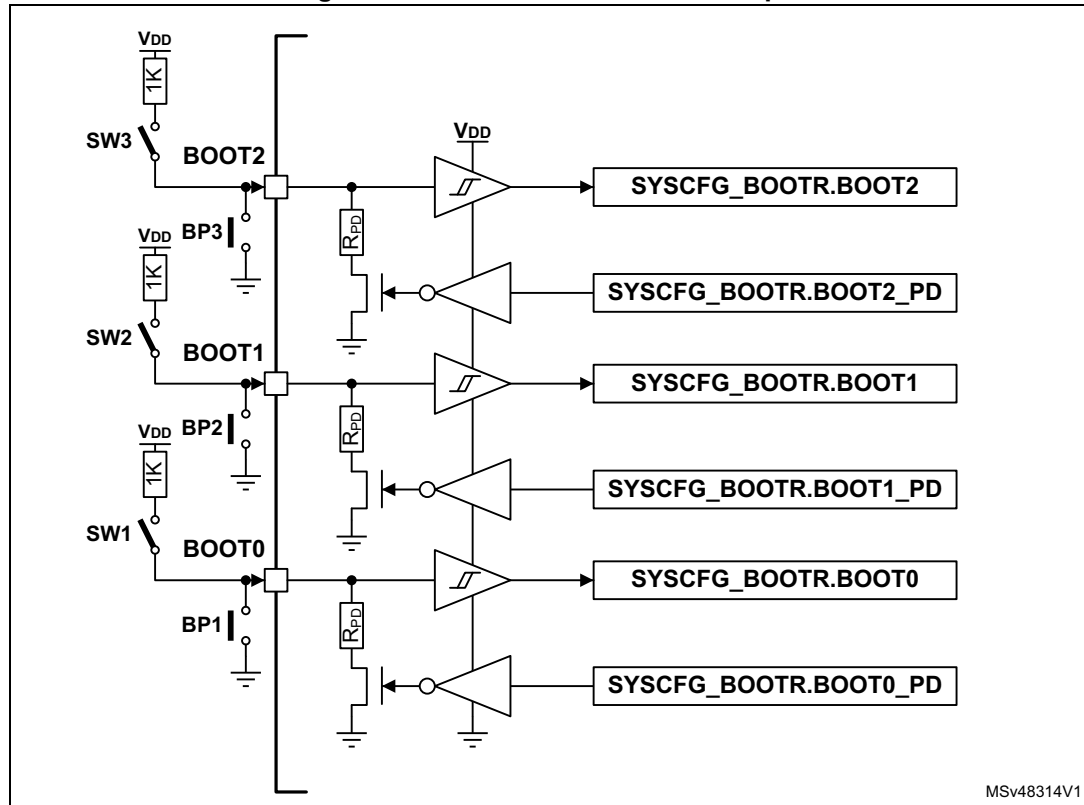

Despite all the recovery cases in software, there is a risk that with wrong or corrupted Flash content (such as: user mistake, bad Flash content programmed, power lost), the system might not start (also known as 'bricked').

Note that on empty Flash, the boot code automatically switches to UART/USB connection.

It might be required to have a way to force use of UART/USB connection in order to allow board Flash re-programming (for example: after sale services, firmware update).

There are also cases of where initial boot is done on a different Flash than regular boot (for example the initial boot from SD-Card, which copies binary data in another Flash like Serial NOR, Serial NAND, eMMC or SLC NAND). This is possible as the initial boot code could set relevant OTP bits to force future boot from the programmed Flash (see Figure 16). This allows a simplified and flexible mass production without intervention on BOOT pins.

The typical connections examples for final board are described in Figure 15.

The 'switches' could be done by various ways: pushbutton, solder bridges, connector contacts, test points, etc..., but assumed 'open' by default during normal product boot to avoid current flow in external resistors.

Note that OTP configuration could force or forbid any of the boot sources in order to satisfy product security requirements.

Figure 15. BOOT pins typical connection schematics

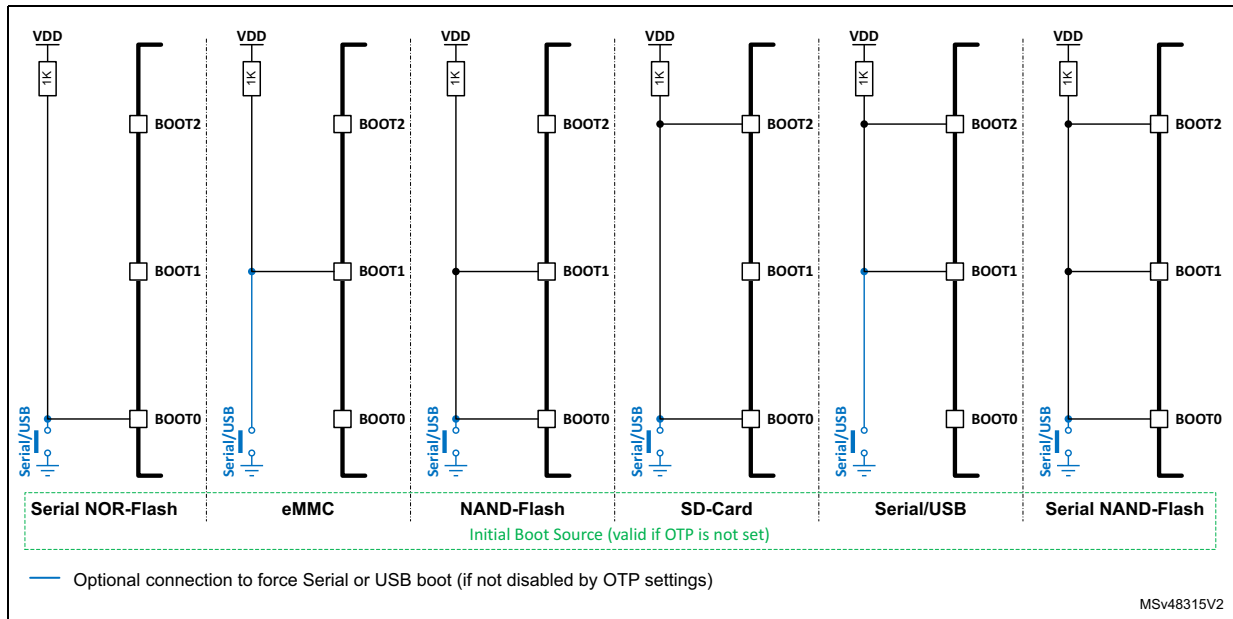

7.3 Embedded boot loader mode

This embedded boot loader is located in the BootROM memory.

For additional information, refer to *USB DFU/USART protocols used in STM32MP1 Series bootloaders* (AN5275) ([Table 1](#)).

During boot, the QUADSPI, FMC, SDMMC and USART peripherals operates with the internal 64 MHz oscillator (HSI).

The USB OTG HS device, however, can function only if an external clock (HSE) is present with a default frequency of either 8, 10, 12, 14, 16, 20, 24, 28, 32, 36, 40 or 48 MHz (automatic detection). Alternatively, a fixed 24, 25 or 26 MHz frequency could be used with OTP settings).

Figure 16. Simplified boot flow

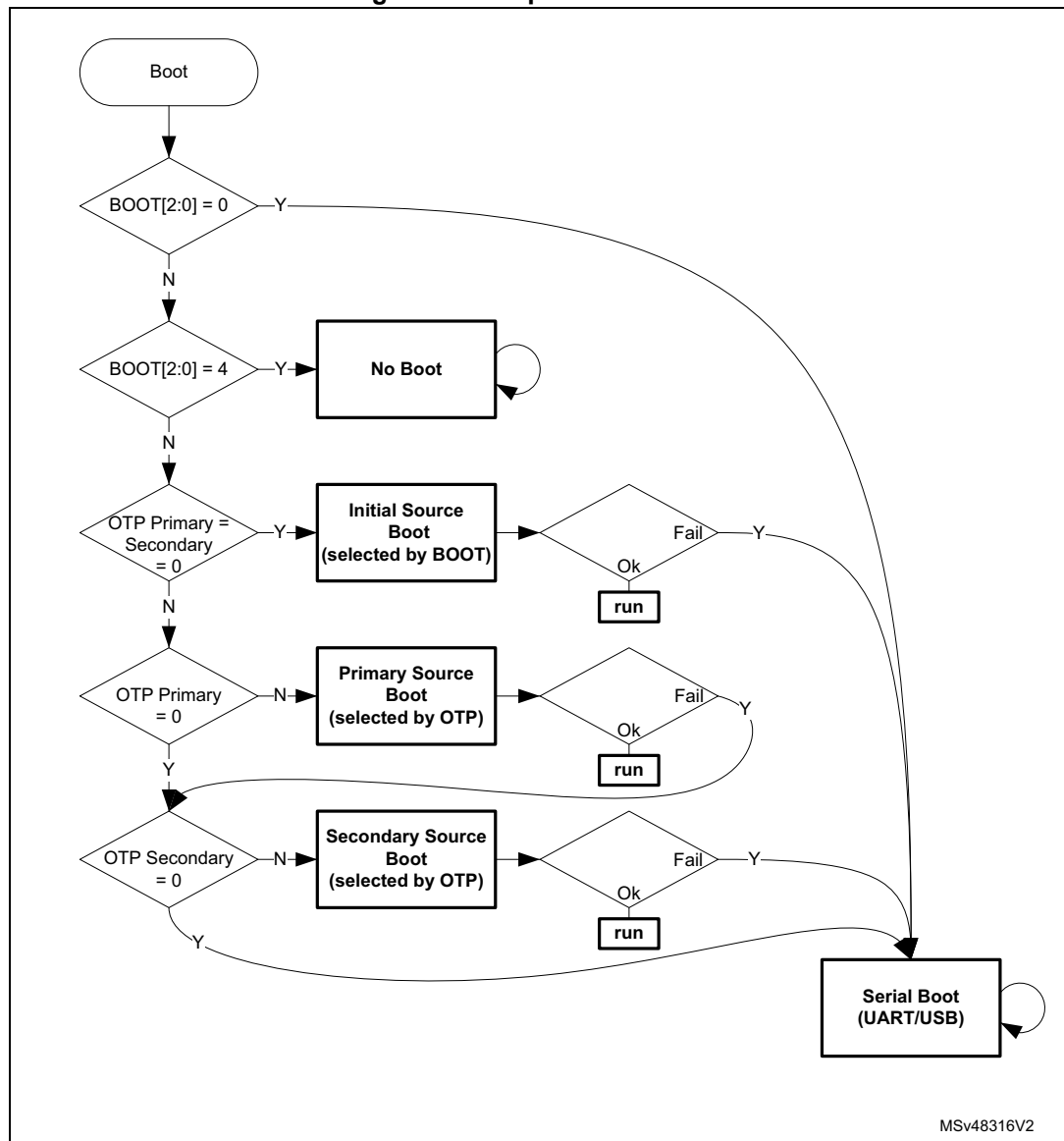

MSv48316V2

8 Debug management

8.1 Introduction

The Host/target interface is the hardware equipment that connects the host to the application board. This interface is made of three components: a hardware debug tool, a JTAG or SWD connector and a cable connecting the host to the debug tool.

Figure 17 shows the connection of the host to the evaluation board.

Figure 17. Host-to-board connection

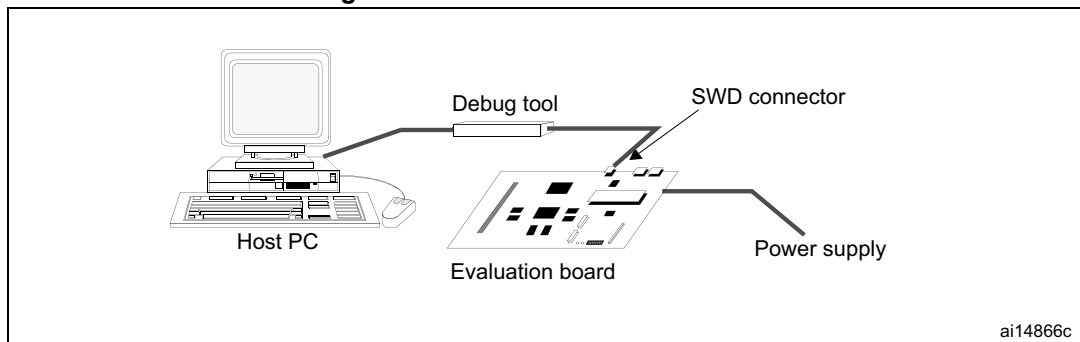

8.2 SWJ debug port (serial wire and JTAG)

The STM32MP15x lines core integrates the Serial Wire / JTAG debug port (SWJ-DP). It is an Arm® standard CoreSight™ debug port that combines a JTAG-DP (5-pin) interface and a SW-DP (2-pin) interface.

- The JTAG debug port (JTAG-DP) provides a 5-pin standard JTAG interface to the AHP-AP port
- The serial wire debug port (SW-DP) provides a 2-pin (clock + data) interface to the AHB-AP port

The two pins of the SW-DP are multiplexed with two of the five JTAG pins of the JTAG-DP.

8.3 Pinout and debug port pins

8.3.1 Internal pull-up and pull-down resistors on JTAG pins

To avoid any uncontrolled I/O levels, the STM32MP15x lines embed internal pull-up and pull-down resistors on JTAG pins:

- NJTRST: Internal pull-up
- JTDI: Internal pull-up
- JTDO-TRACESWO: Internal pull-up
- JTMS-SWDIO: Internal pull-up
- JTCK-SWCLK: Internal pull-down

Note: The JTAG IEEE standard recommends to add pull-up resistors on TDI, TMS and nTRST but there is no special recommendation for TCK. However, for the STM32MP15x lines, an integrated pull-down resistor is used for JTCK.

Having embedded pull-up and pull-down resistors removes the need to add external resistors.

8.3.2 Debug port connection with standard JTAG connector

Figure 18 shows the connection between the STM32MP15x lines and a standard JTAG/SWD connector.

Figure 18. JTAG/SWD MIP110 connector implementation example

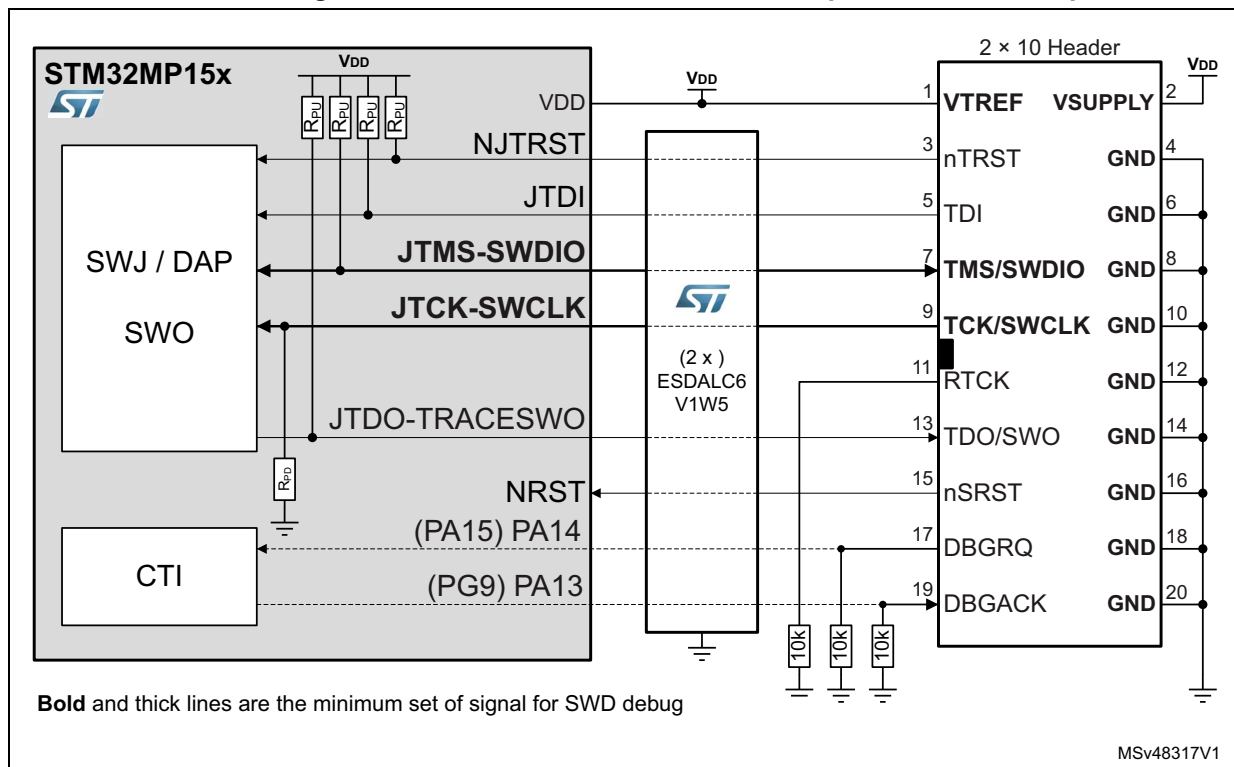

Note: The single wire trace on TRACESWO pin is only available for Cortex-M4 core. To trace all cores activity, a parallel trace port must be used (see Section 8.3.4: Parallel trace and HDP).

8.3.3 Debug port and UART connection with STDC14 connector

Figure 19 shows the connection between the STM32MP15x lines and a STDC14 connector including UART virtual com port connection.

Reference example for STDC14 header is FTSH-107-01-L-DV-K-A

Figure 19. JTAG/SWD/UART VCP STDC14 connector implementation example

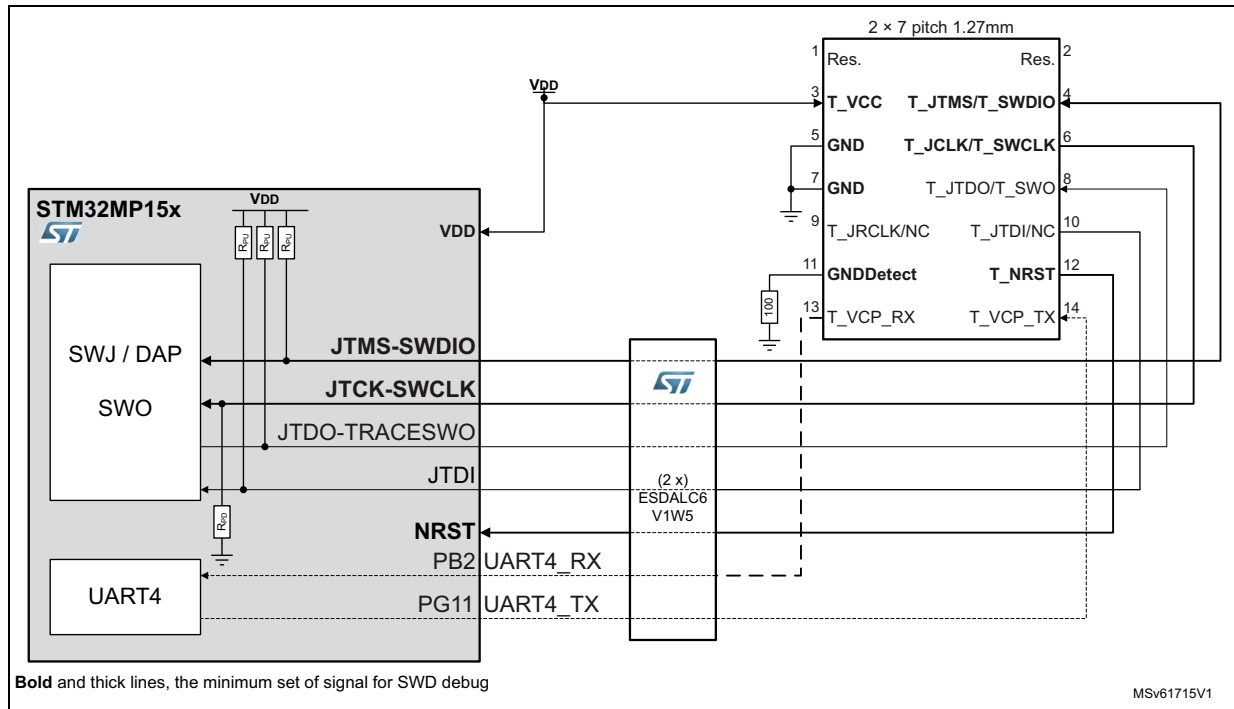

Note: The single wire trace on TRACESWO pin is only available for Cortex-M4 Core. To trace all cores activity, a parallel trace port must be used (see Section 8.3.4: Parallel trace and HDP).

Note: STDC14 connector is respecting (from pin 3 to pin 12) the Arm10 pinout (Arm Cortex debug connector).

8.3.4 Parallel trace and HDP

Parallel trace

TRACED[15:0] and TRACECLK signals are available as alternate functions on IOs pins. The user could select number of trace data $N = 1, 2, 4, 8$ or 16 pins. Less trace data mean lower available trace bandwidth, so less information could be traced (such as the number of trace sources, code and/or data tracing) without trace overrun (there is a 8 Kbytes buffer in STM32MP15x lines). For each product, a trade-off between available features and trace bus could lead to have reduced feature while using trace during product development.

The trace is compliant to Arm® CoreSight™ trace and needs a dedicated tracing tool in order to be interpreted and correlated with debugging done through SWD or JTAG.

For more information on the Trace Port Interface CoreSight™ component, refer to product reference manual and the Arm® CoreSight™ SoC-400 technical reference manual.

Note that for efficient tracing bandwidth, TRACECLK should run as fast as possible while maintaining good signal integrity on all parallel trace signals. This is dependent on board and connector choices, GPIO strength settings (GPIO_OSPEEDR registers) and V_{DD} voltage.

When using $V_{DD} = 1.8$ V, a setting in the OTP bit and the register SYSCFG_IOCTRLSETR (HSLVEN_TRACE bit) could be required to ensure the best speed on pads used on trace signals.

Warning: HSLVEN_xxx must not be set when V_{DD} is above 2.7 V otherwise permanent IC damage could occur.

Figure 20. Parallel trace port with JTAG/SWD on Mictor-38 implementation example

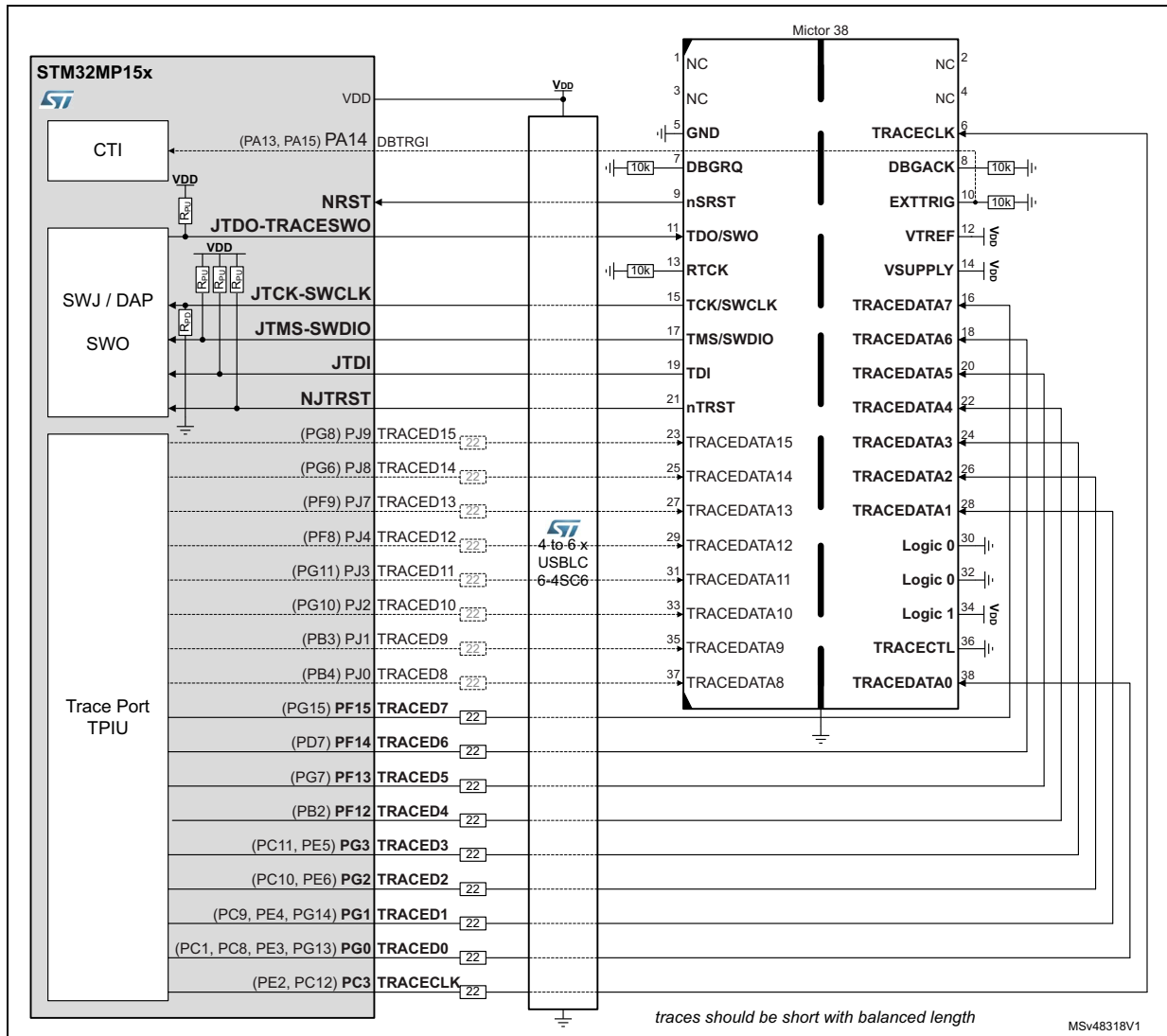

Hardware debug port

Some internal signals are available for deep debugging. Internal knowledge and an oscilloscope or logic analyzer are needed. For more information, refer to product reference manual and datasheet.

8.3.5 Debug triggers and LEDs

The CoreSight™ Cross-Trigger Interface (CTI) are available on pins as DBTRGI and DBTRGO.

DBTRGI could be generated by external user signal and could be programmed inside CoreSight™ components to start/stop traces or enter specific core(s) in debug mode (break).

DBTRGO could be generated by CTI to see externally that a trigger condition has been reached by one of the CoreSight™ component (core break, trace started, etc...).

DBTRGO could be made available on PA13, PA14 or PG9.

DBTRGI could be made available on PA13, PA14 or PA15.

PA13 specific behavior (see boot documentation for details):

- During boot phase, in case of boot failure, the PA13 pin is set to low open-drain (that is the error LED lights bright).
- During UART/USB boot, the PA13 pin toggles open-drain at a rate of about 5 Hz until a connection is started (that is error LED blinks fast).
- With BOOT[2:0] = 0b100 (no boot, used for specific debug), PA13 toggles open-drain at a rate of about 5 kHz (that is error LED lights weak).
- In all other cases, the PA13 is kept in its reset value, that is high-z until software setting.

It is a good idea to put a red LED on PA13 as shown in [Figure 21](#).

LEDs are useful for quick visual signaling of system activity. So, it is a good choice to use PA13 and PA14. This does not avoid usage of DBTRGI and DBTRGO on PA13 or PA14 for debug (assuming the software stops controlling LEDs during this specific debug).

Figure 21. Example of LED connections

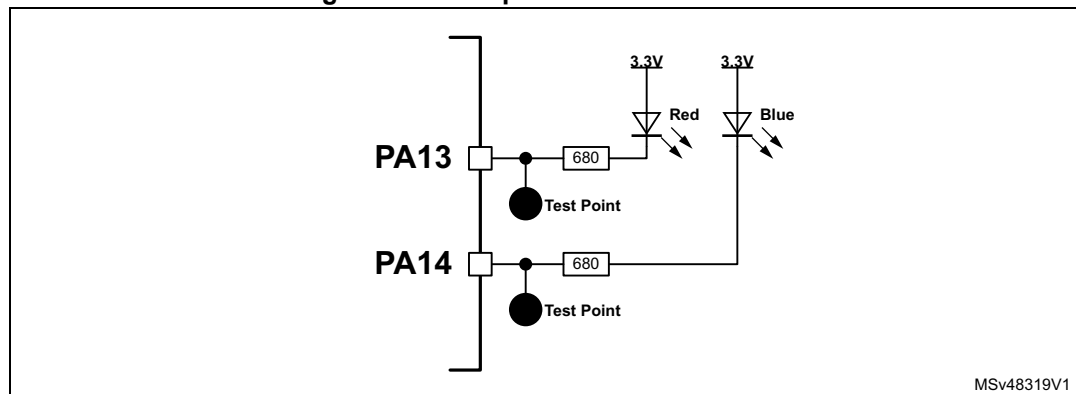

9 Recommendations

9.1 Printed circuit board

For technical reasons, it is mandatory to use a multilayer printed circuit board (PCB) with a separate layer dedicated to ground (V_{SS}) and another layer dedicated for power supplies like the V_{DD} and V_{DDCORE} . This provides good decoupling and a good shielding effect.

9.2 Component position

A preliminary layout of the PCB must separate the different circuits according to their EMI contribution in order to reduce cross-coupling on the PCB, that is noisy, high-current circuits, low-voltage circuits, and digital components.

9.3 Ground and power supply (V_{SSx} , V_{DDx})

Due to large power and high frequencies involved in STM32MP15x lines, it is mandatory to use at least 4 layers PCB with dedicated power planes for V_{SSx} and V_{DDx} .

9.4 IO speed settings

It is important to set the right output drive on IOs in order to have sufficient rise and fall time, but also avoid additional ringing and noise.

When there is no specific requirements for IO speed, it is mandatory to set OSPEEDR to 0.

As a first approximation, the following drawing and tables could be used to quickly choose the right setting to apply according to signal frequency and capacitive load. This setting might need to be tailored in case of signal integrity issue.

In most cases, IO compensation needs to be enabled in SYSCFG. Refer to product datasheet for more details.

Note: In case of asynchronous or single edge clocked data lanes (such as SDR), the maximum data frequency toggle is effectively half the data rate. For example an SPI running at 10 Mbits/s has a maximum frequency of 5 MHz on data signal (for example output serial data 01010101...), but 10 MHz on the clock signal. On dual edge clocked data lanes (such as DDR), the clock and data have same maximum toggling frequency.

Note: The HSLVEN_xxx bits are not taken into account if the OTP bit PRODUCT_BELOW_2V5 = 0 (default state).

Note: Setting HSLVEN_xxx=1 and product_below_2V5=1 while VDD > 2.7V can damage the IC.

Figure 22. IO speed summary with various loads and voltages

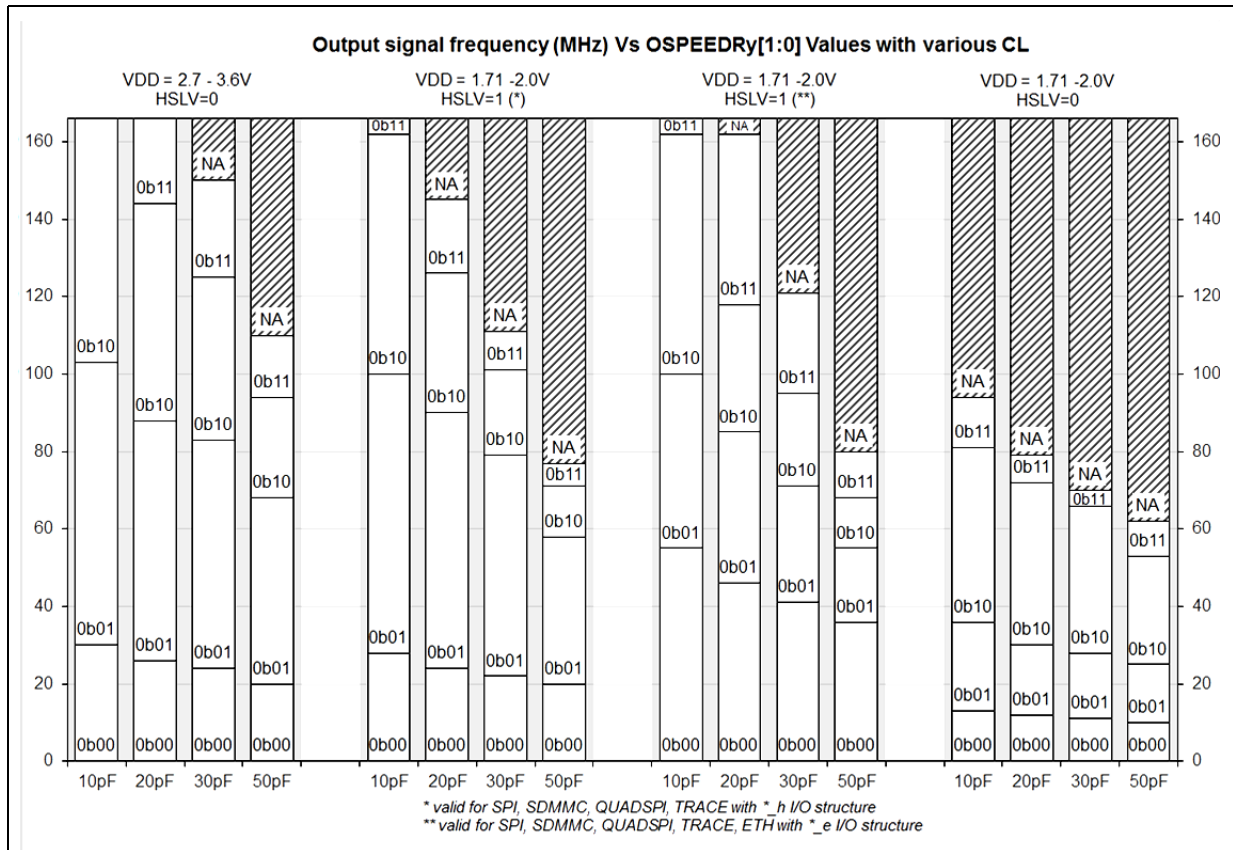

Table 13. OSPEEDR setting example for VDD = 3.3 V typ

Peripheral	Signals	Toggle rate (MHz)	OSPEEDR CL=30 pF		OSPEEDR CL=10 pF	
FMC async	Data/Controls	50	1	Medium speed	1	Medium speed
FMC sync	CLK	100	2	High speed	1	Medium speed
	Data/Controls	50	1	Medium speed	1	Medium speed
QUADSPI (SDR)	CLK	133	2	High speed ⁽¹⁾	2	High speed
	Data/Controls	66.5	1	Medium speed	1	Medium speed
QUADSPI (DDR)	All	66.5	1	Medium speed	1	Medium speed
LTDC (HDMI) ⁽²⁾	CLK	74.25	1	Medium speed	1	Medium speed
	Data/Controls	37.125	1	Medium speed	1	Medium speed
LTDC ⁽²⁾	CLK	90	2	High speed	1	Medium speed
	Data/Controls	45	1	Medium speed	1	Medium speed
LTDC	CLK	48	1	Medium speed	1	Medium speed
	Data/Controls	24	0	Low speed	0	Low speed
TIM/LPTIM	All	5	0	Low speed	0	Low speed

Table 13. OSPEEDR setting example for VDD = 3.3 V typ (continued)

Peripheral	Signals	Toggling rate (MHz)	OSPEEDR CL=30 pF		OSPEEDR CL=10 pF	
I2C	All	1	0	Low speed	0	Low speed
USART	All	5	0	Low speed	0	Low speed
SPI	CLK	50	1	Medium speed	1	Medium speed
	Data/Controls	25	1	Medium speed	0	Low speed
SAI	MCLK	15	0	Low speed	0	Low speed
	CLK	1	0	Low speed	0	Low speed
	Data/Controls	0.5	0	Low speed	0	Low speed
MDIOS	All	5	0	Low speed	0	Low speed
SDMMC (SDR)	CLK	133	2	High speed ⁽¹⁾	2	High speed
	Data/Controls	66.5	1	Medium speed	1	Medium speed
SDMMC (DDR)	All	52	1	Medium speed	1	Medium speed
FDCAN	All	5	0	Low speed	0	Low speed
ETH (MII)	CLK	50	1	Medium speed	1	Medium speed
	Data/Controls	25	1	Medium speed	0	Low speed
ETH (RMII)	All	50	1	Medium speed	1	Medium speed
ETH (GMII)	CLK	125	2	High speed	2	High speed
	Data/Controls	62.5	1	Medium speed	1	Medium speed
ETH (RGMII)	All	125	2	High speed	2	High speed
ETH (MDIO)	MDIO	2.5	0	Low speed	0	Low speed
TRACE	All	133	3	Very high speed	2	High speed
		100	2	High speed	1	Medium speed

1. Value for CL=20 pF.

2. Requires External Oscillator for HSE.

Table 14. OSPEEDR setting example for VDD = 1.8 V typ.⁽¹⁾

Peripheral	Signals	Toggling rate (MHz)	OSPEEDR CL=30 pF		OSPEEDR CL=10 pF	
FMC async	Data/Controls	50	2	High speed	2	High speed
FMC sync	CLK	69	3	Very high speed	3	Very high speed
	Data/Controls	34.5	2	High speed	1	Medium speed
QUADSPI (SDR) ⁽²⁾	CLK	133	3	Very high speed ⁽³⁾	2	High speed
	Data/Controls	66.5	1	Medium speed	1	Medium speed
QUADSPI (DDR) ⁽²⁾	All	66.5	1	Medium speed	1	Medium speed
LTDC (HDMI)	CLK	74.25	3	Very high speed ⁽³⁾	3	Very high speed
	Data/Controls	37.125	2	High speed	2	High speed

Table 14. OSPEEDR setting example for VDD = 1.8 V typ.⁽¹⁾ (continued)

Peripheral	Signals	Toggling rate (MHz)	OSPEEDR CL=30 pF		OSPEEDR CL=10 pF	
LTDC	CLK	69	3	Very high speed	3	Very high speed
	Data/Controls	34.5	2	High speed	1	Medium speed
TIM/LPTIM	All	5	0	Low speed	0	Low speed
I2C	All	1	0	Low speed	0	Low speed
USART	All	5	0	Low speed	0	Low speed
SPI ⁽⁴⁾	CLK	50	1	Medium speed	1	Medium speed
	Data/Controls	25	1	Medium speed	0	Low speed
SAI	MCLK	15	1	Medium speed	1	Medium speed
	CLK	1	0	Low speed	0	Low speed
	Data/Controls	0.5	0	Low speed	0	Low speed
MDIOS	All	5	0	Low speed	0	Low speed
SDMMC (SDR) ⁽⁵⁾	CLK	133	3	Very high speed ⁽³⁾	2	High speed
	Data/Controls	66.5	1	Medium speed	1	Medium speed
SDMMC (DDR) ⁽⁵⁾	All	52	1	Medium speed	1	Medium speed
FDCAN	All	5	0	Low speed	0	Low speed
ETH (MII) ⁽⁶⁾	CLK	50	1	Medium speed	0	Low speed
	Data/Controls	25	0	Low speed	0	Low speed
ETH (RMII) ⁽⁶⁾	All	50	1	Medium speed	0	Low speed
ETH (GMII) ⁽⁶⁾	CLK	125	3	Very high speed ⁽³⁾	2	High speed
	Data/Controls	62.5	1	Medium speed	1	Medium speed
ETH (RGMII) ⁽⁶⁾	All	125	3	Very high speed ⁽³⁾	2	High speed
ETH (MDIO)	MDIO	2.5	0	Low speed	0	Low speed
TRACE ⁽⁷⁾	All	133	3	Very high speed ⁽³⁾	2	High speed
		100	2	High speed	1	Medium speed

1. HSLVEN_xxx=1 are only taken into account if OTP bit PRODUCT_BELOW_2V5 is set.

2. HSLVEN_QUADSPI=1.

3. Value for CL=20pF.

4. HSLVEN_SPI=1.

5. HSLVEN_SDMMC=1.

6. HSLVEN_ETH=1.

7. HSLVEN_TRACE=1.

9.5 PCB stack and technology

A trade off between the PCB cost and easy electrical connections has to be made. Below examples are either for 4 or 6 layers PCB with only PTH (suited for 0.8mm pitch package) or 4 layers PCB with both PTH and laser drilled vias (suited for 0.5mm pitch package).

Note that some STM32MP15x lines packages with outer ball pitch of 0.5 mm provide power improved center ball matrix with a pitch of 0.65 mm to allow large PTH via in between balls. This ensures better supply connection as well as optimized thermal conductivity than small buried laser drilled vias.

Figure 23. 6 layer PCB stack example

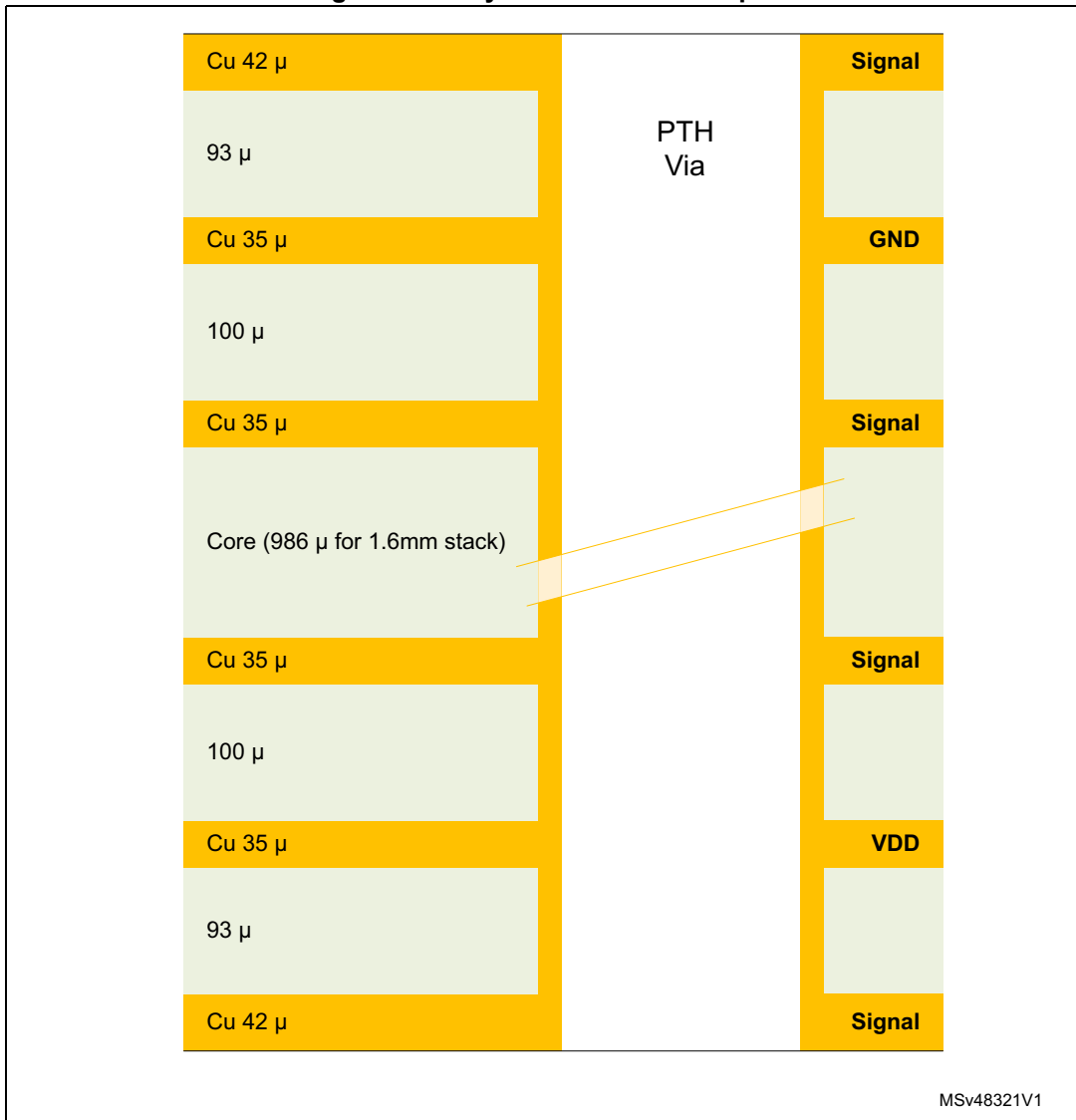

Figure 24. 4 layer PCB stack example

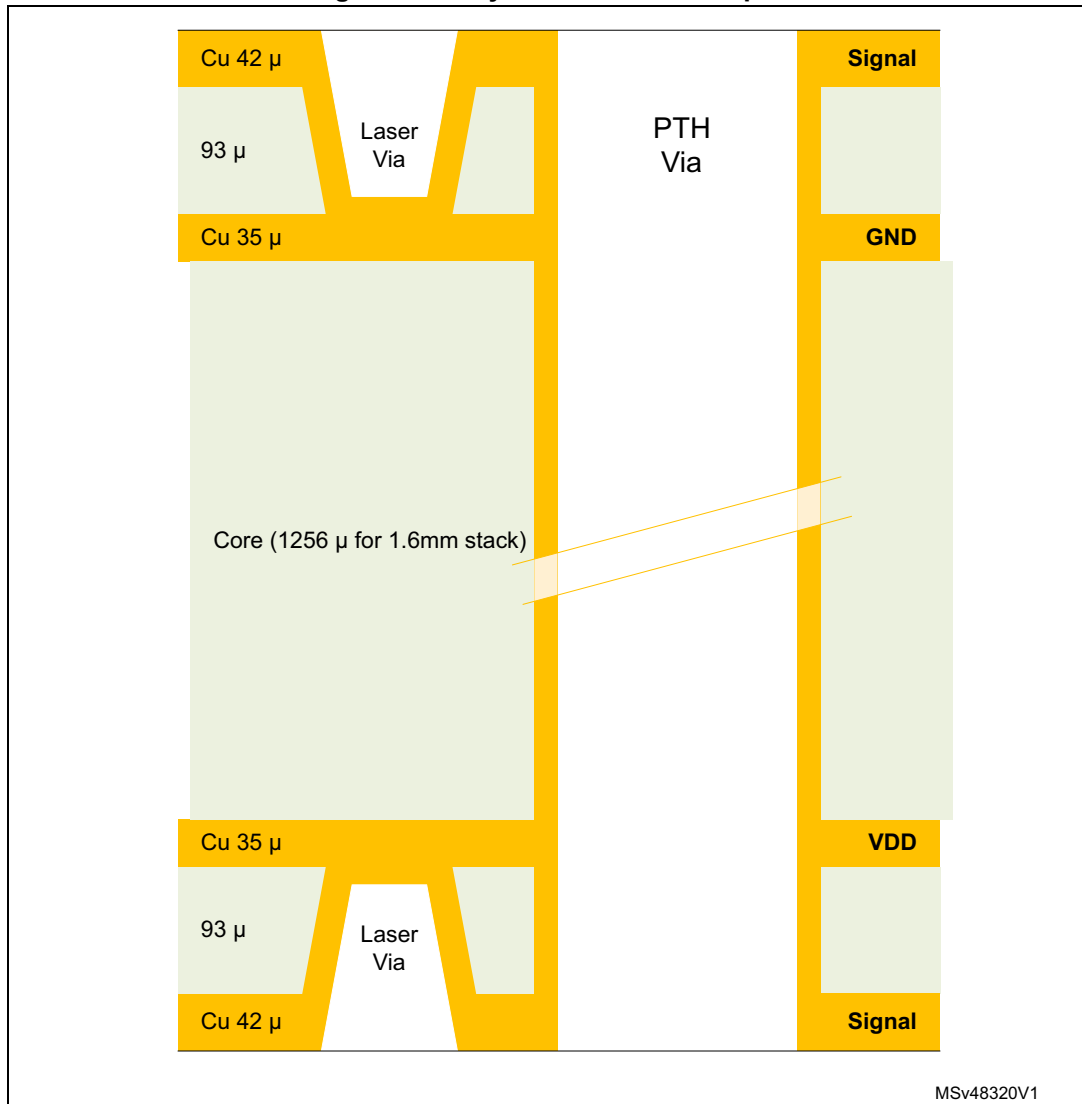

Figure 25. PCB rule example for 0.8 mm pitch package

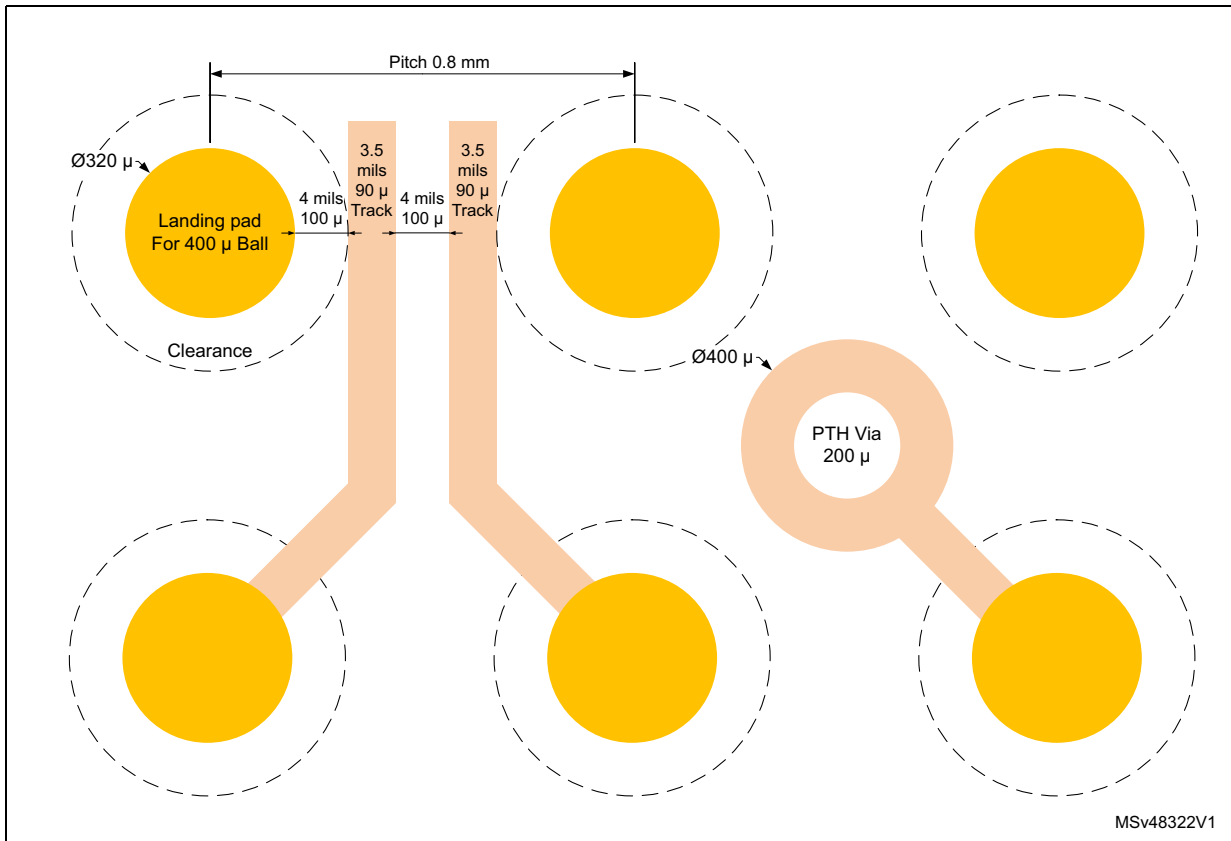

Figure 26. PCB rule example for 0.5 mm pitch package

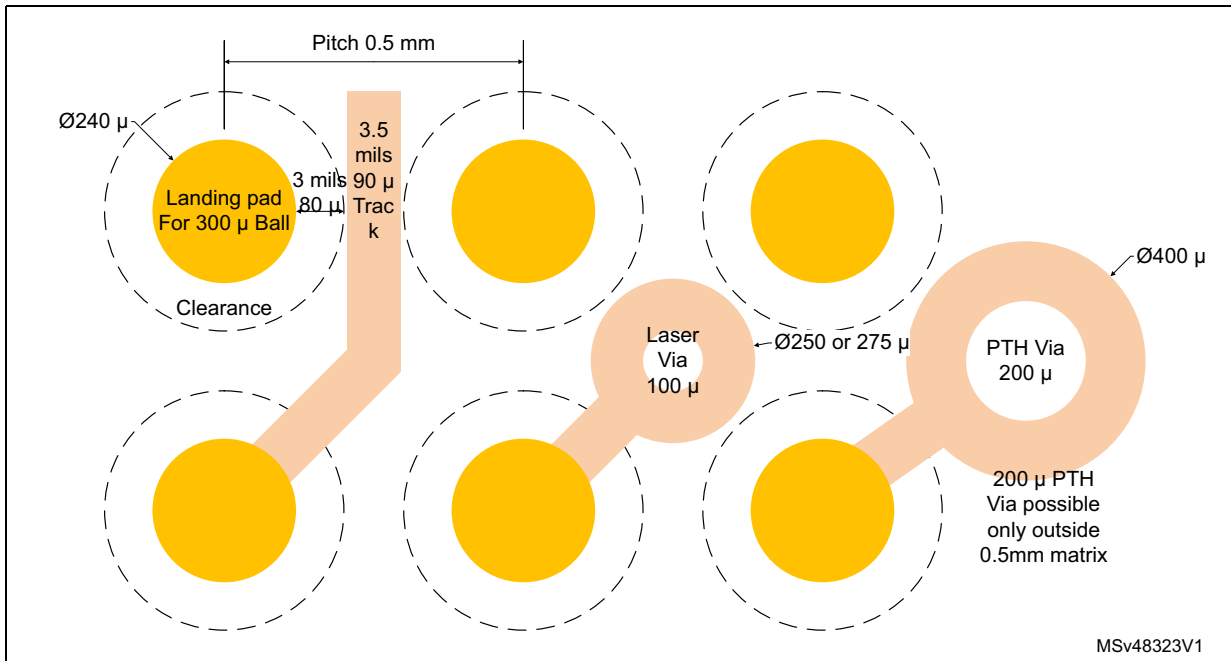
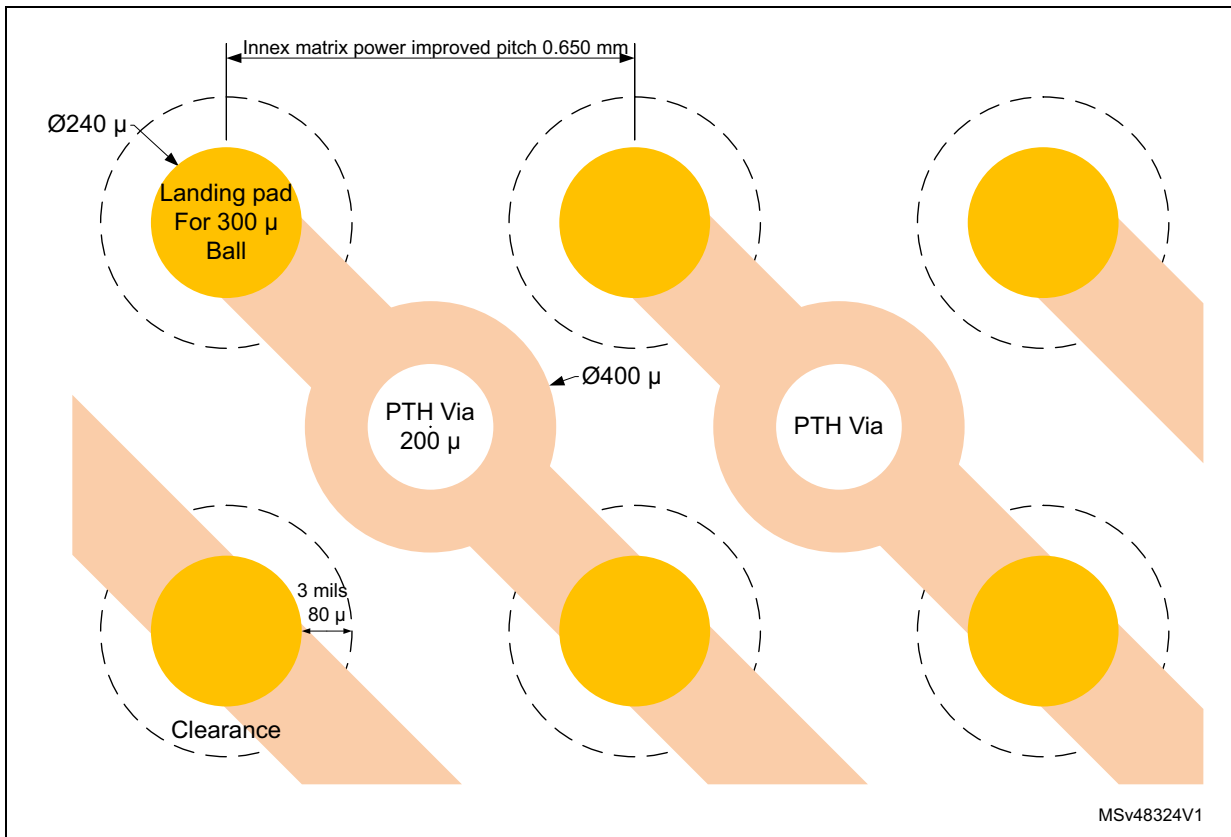

Figure 27. PCB rule example for inner balls with 0.65mm power improved pitch



9.6 Decoupling

All the power supply and ground pins must be properly connected to the power supplies. These connections, including pads, tracks and vias should have as low impedance as possible. This is typically achieved with thick track widths and, preferably, the use of dedicated power supply planes in multilayer PCBs.

In addition, each power supply pair should be decoupled with ceramic capacitors (most of the time 100 nF or 1 μ F, see [Table 4](#)). These capacitors need to be placed as close as possible to, or below, the appropriate pins on the underside of the PCB. Exact values might depend on the application. [Figure 28](#) shows the typical layout of such a decoupling placement.

Figure 28. Example of decoupling layout

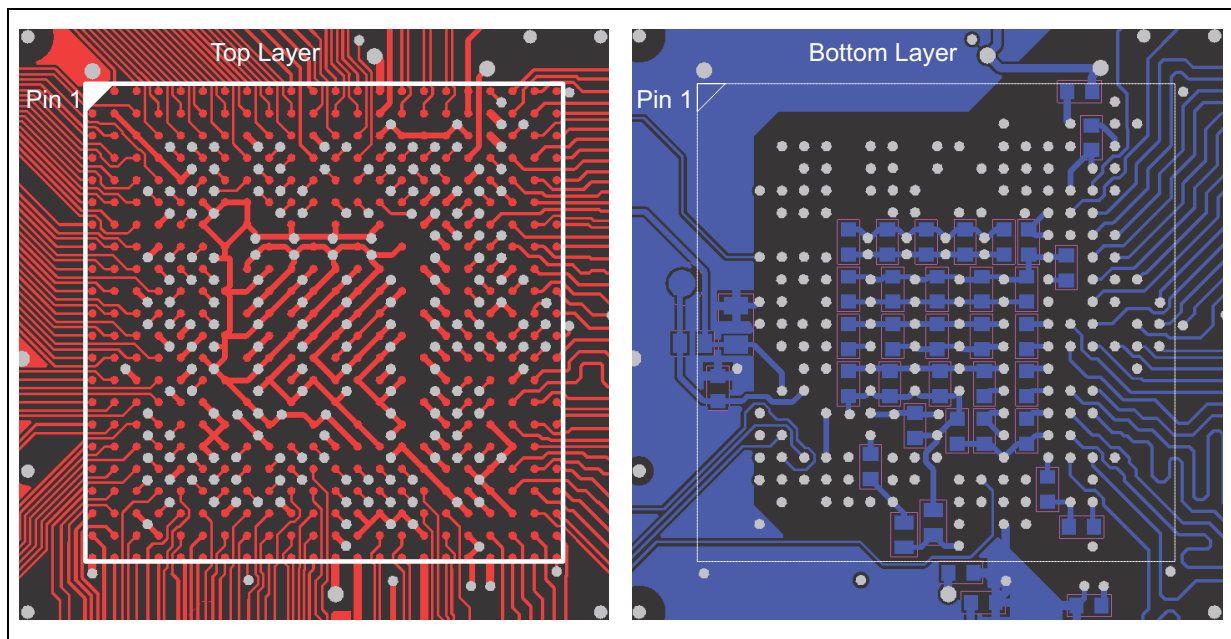

1. PTH via connecting supplies and decoupling capacitors to internal planes are visible in gray.

9.7 ESD/EMI protections

ElectroStatic Discharge (ESD) and ElectroMagnetic Interference (EMI) should be taken into account from the beginning of a product development as it could be very complex and expensive to add them later.

ESD and EMI are driven by global standards (such as IEC 61000, JESD 22) which in most countries require a certification to allow mandatory marking to be applied on a product (such as CE, FCC).

ESD and EMI are also driven by standardized interface certification or requirements (for example USB).

Although the STM32MP15x lines embed device level ESD protection, the final product protection should be done by external components, more especially on interfaces having external user access in the final product (such as Ethernet, USB, SD-card).

Some components provide ESD protection as well as EMI common mode filtering (for example ECMF02-2AMX6 used on USB).

Some examples of ESD/EMI protections are provided in [Section 10: Reference design examples](#).

For more details, refer to *EMC design guide for ST microcontrollers* application note (AN1709).

9.8 Sensitive signals

When designing an application, the ElectroMagnetic Compatibility (EMC) performance can be improved by closely studying:

- Signals for which a temporary disturbance affects the running process permanently (the case of interrupts and handshaking strobe signals, and not the case for LED commands).
For these signals, a surrounding ground trace, shorter lengths and the absence of noisy and sensitive traces nearby (crosstalk effect) improve the EMC performance. For digital signals, the best possible electrical margin must be reached for the two logical states and slow Schmitt triggers are recommended to eliminate parasitic states.
- Noisy signals (clock, etc.)
- Sensitive signals (high impedance, etc.)

For more details, refer to *EMC design guide for ST microcontrollers* application (AN1709).

9.9 Unused I/Os and features

The STM32MP15x lines are designed for a wide range of applications and often a particular application does not use 100% of the resources.

To increase the EMC performance, unused clocks, counters or I/Os, should not be left free, for example I/Os should be set to “0” or “1” (pull-up or pull-down to the unused I/O pins) and unused features should be “frozen” or disabled.

10 Reference design examples

10.1 Description

The following sections are example to help the user to connect major and critical interfaces to the STM32MP15x lines.

10.1.1 Clock

Two clock sources are used for STM32MP15x lines, with the following choice:

- LSE: 32.768 kHz crystal for the embedded RTC
- HSE: 24 MHz crystal or external oscillator as STM32MP15x lines main clock

Refer to [Section 6: Clocks on page 28](#).

Figure 29. HSE recommended schematics for both oscillator/crystal options

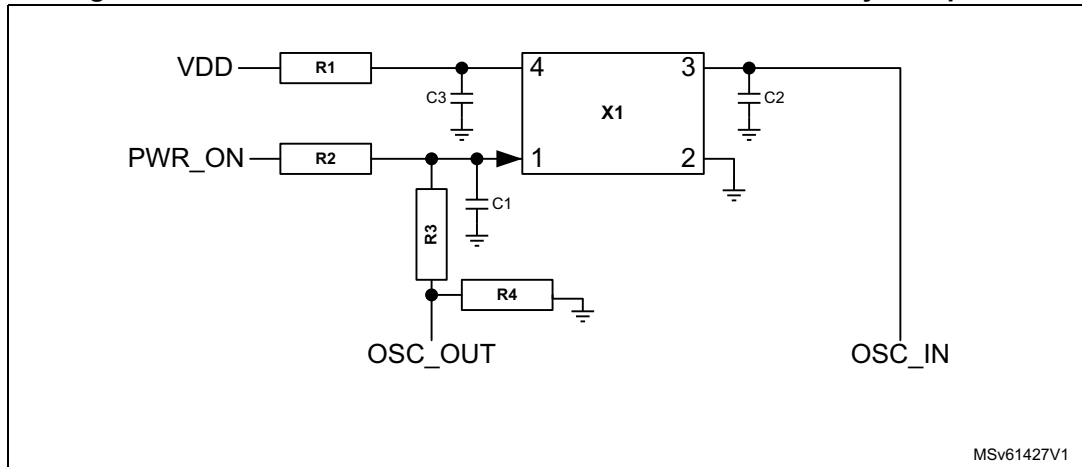

MSv61427V1

Table 15. HSE BOM for oscillator or crystal

-	Oscillator	Crystal
X1	NZ2016SH 24 MHz	NX2016SA 24 MHz
R1	10 ohms	-
R2	10 Kohms	-
R3	-	0 ohm
R4	1Kohm	-
C1	-	6.8 pF
C2	-	6.8 pF
C3	10 nF	-

10.1.2 Reset

The NRST reset signal in [Figure 4](#) is active low. The reset sources include:

- Reset button
- Debugging tools via the JTAG connector

Refer to [Section 4.3: Reset and power supply supervisor on page 17](#).

10.1.3 Boot mode

The boot option is configured by setting permanent wires or switches SW3 (BOOT2), SW2 (BOOT1) and SW1 (BOOT0) and internal OTP. Refer to [Section 7: Boot configuration on page 32](#).

In case of the UART boot using one of the possible U(S)ARTx_RX pins, (refer to [STM32MP1 Series wiki](#)), to avoid a floating signal sent to the host, until the initialization character is received and decoded by the BootROM, it is required to have a 10 kOhm V_{DD} pull-up on the respective U(S)ARTx_TX pin.

Table 16. UART possible boot pins

Peripheral	Signal	Pin
USART2	RX	PA3
	TX	PA2
USART3	RX	PB12
	TX	PB10
UART4 ⁽¹⁾	RX	PB2
	TX	PG11
UART5	RX	PB5
	TX	PB13
USART6	RX	PC7
	TX	PC6
UART7	RX	PF6
	TX	PF7
UART8	RX	PE0
	TX	PE1

1. Recommended default UART for Linux console (that is as VCP on STLINK STDC14 connector).

10.1.4 SWD / JTAG interface

The reference design shows the connections between the STM32MP15x lines and some standard connector. Refer to [Section 8: Debug management on page 36](#).

Note: If available, it is recommended to connect the debugger probe system reset pin to NRST in order to be able to reset the application from the debugger.

10.1.5 Power supply

Refer to [Section 4: Power supplies on page 11](#).

Discrete supplies example with 3.3 V I/Os with DDR3L

This reference design example targets a simple 3.3 V I/Os platform with low cost DDR3L without emphasis on power reduction. The Sleep/Stop/Standby modes are supported. LP-Stop and low power Standby with DDR3L retention could be supported but might have little interest due to the use of DDR3L which has not a low power target for self-refresh.

Refer also to STM32MP151, STM32MP153 and STM32MP157 discrete power supply hardware integration (AN5256).

Figure 30. Discrete supplies example 3.3 V I/Os with DDR3L

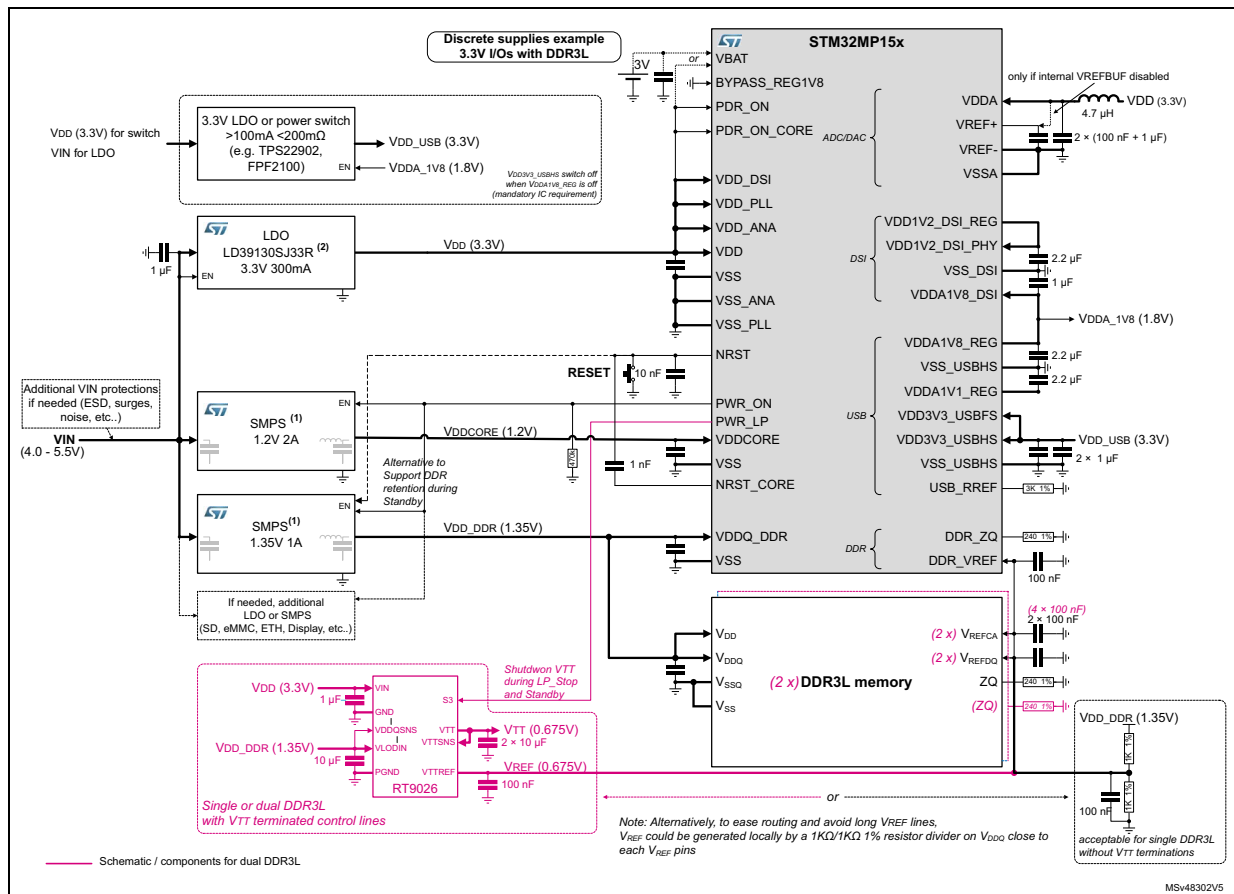

1. Additional SMPS components not shown.
2. Smaller NCP161AFCT330 could also be used.

PMIC supplies example 3.3 V I/Os with DDR3L

This reference design example targets a complex 3.3 V I/Os platform with low cost DDR3L and high integration PMIC. Usually, all platform components can be powered by the PMIC. Full power supply control is supported thanks to PMIC I2C and side band signals. The Sleep/Stop/Standby modes are supported. See PMIC documentations for details of PMIC components.

Figure 31. PMIC example 3.3 V I/Os with DDR3L

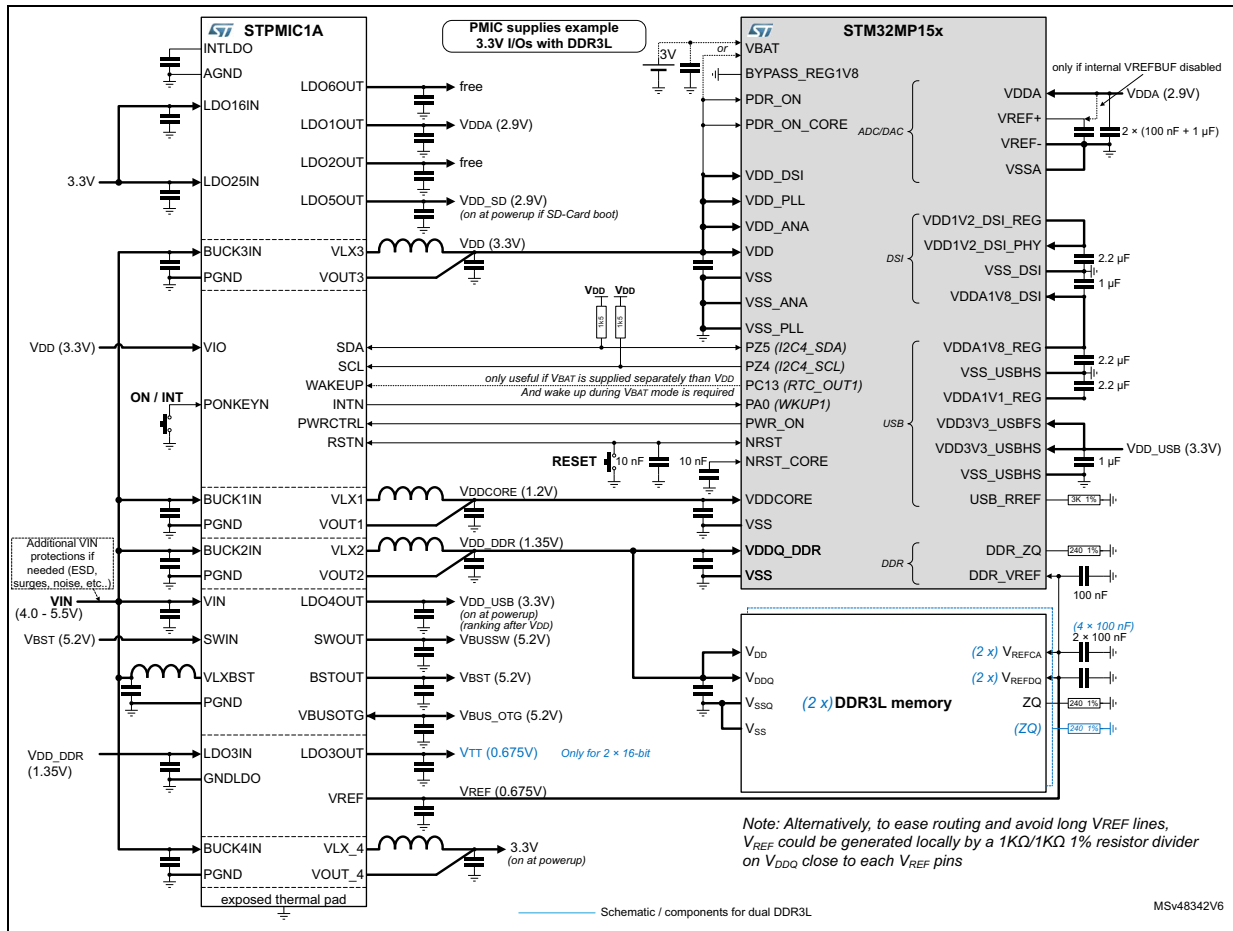

PMIC supplies example 1.8 V I/Os with LPDDR2/LPDDR3

This reference design example targets a complex 1.8 V I/Os platform with low power LPDDR2/LPDDR3 and high integration PMIC. Usually, all platform components can be powered by the PMIC. The full power supply control is supported thanks to PMIC I2C and side band signals. The Sleep/Stop/Standby modes are supported as well as very low power Standby with LPDDR2/LPDDR3 retention. See PMIC documentations for details of PMIC components

Figure 32. PMIC example 1.8 V I/Os with LPDDR2/LPDDR3

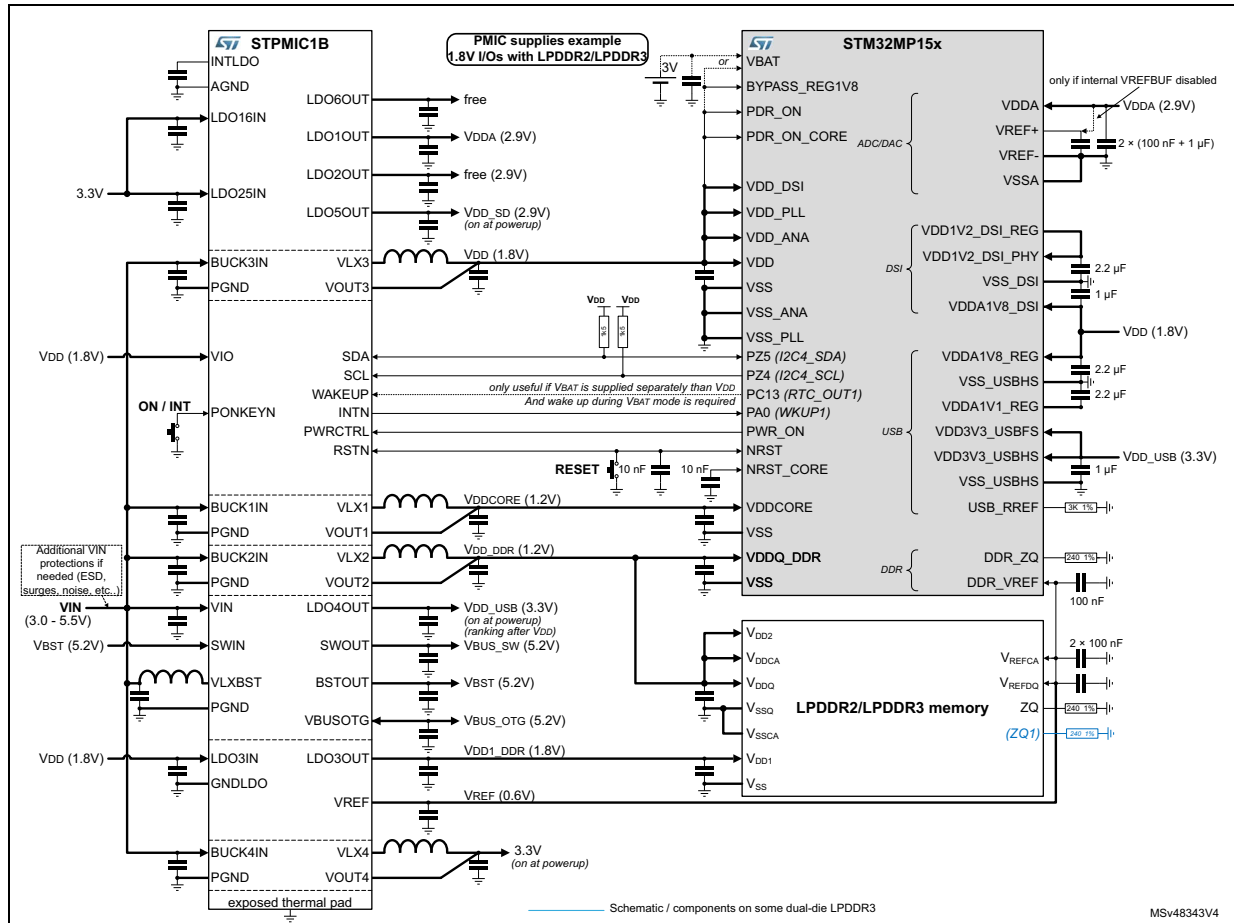

10.1.6 DDR3/DDR3L SDRAM

The DDR3 differs from DDR3L only by different supply voltage (1.5 V vs 1.35 V) and V_{REF} level (0.75 V vs 0.675 V). DDR3L has superseded most DDR3 designs.

A 240 Ohm 1% resistor should be connected between DDR_ZQ and V_{SS} . This resistor must not be shared with ZQ resistors required on each DDR3/DDR3L components.

In case of 2x16-bits device, the impedance matching resistor network connected on termination voltage (V_{TT}) supply should be placed as close as possible off the last device. 'Fly-by' routing techniques must be used to avoid any impedance discontinuities. Values in example below should work in most cases, but could be tailored to each side IO drive strengths and PCB impedance.

Figure 33. DDR3L 16/32 bits connection example

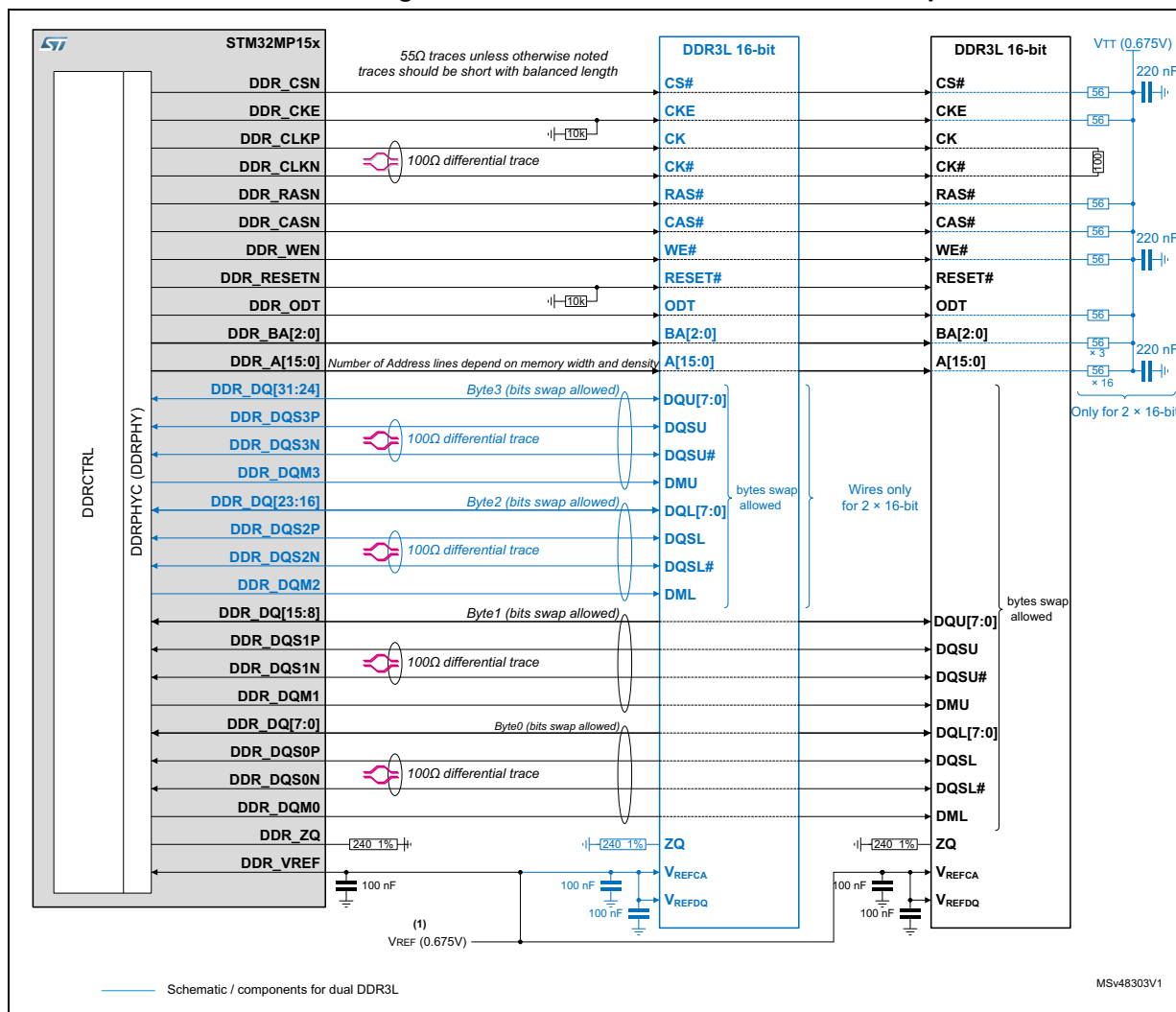

1. Alternatively, to ease routing and avoid long V_{REF} lines, V_{REF} could be generated locally by a 1KOhm/1KOhm 1% resistor divider on V_{DDQ} close to each V_{REF} pins.
2. Supplies and decoupling capacitors not shown.

Detailed routing examples are described in *STM32MP1 Series DDR memory routing guidelines* application note (AN5122).

10.1.7 LpDDR2/LpDDR3 SDRAM

A 240 Ohm 1% resistor should be connected between DDR_ZQ and V_{SS}. This resistor must not be shared with one or more ZQ resistors required on LPDDR2/LPDDR3 component.

Figure 34. LPDDR2/LPDDR3 32-bits connection example

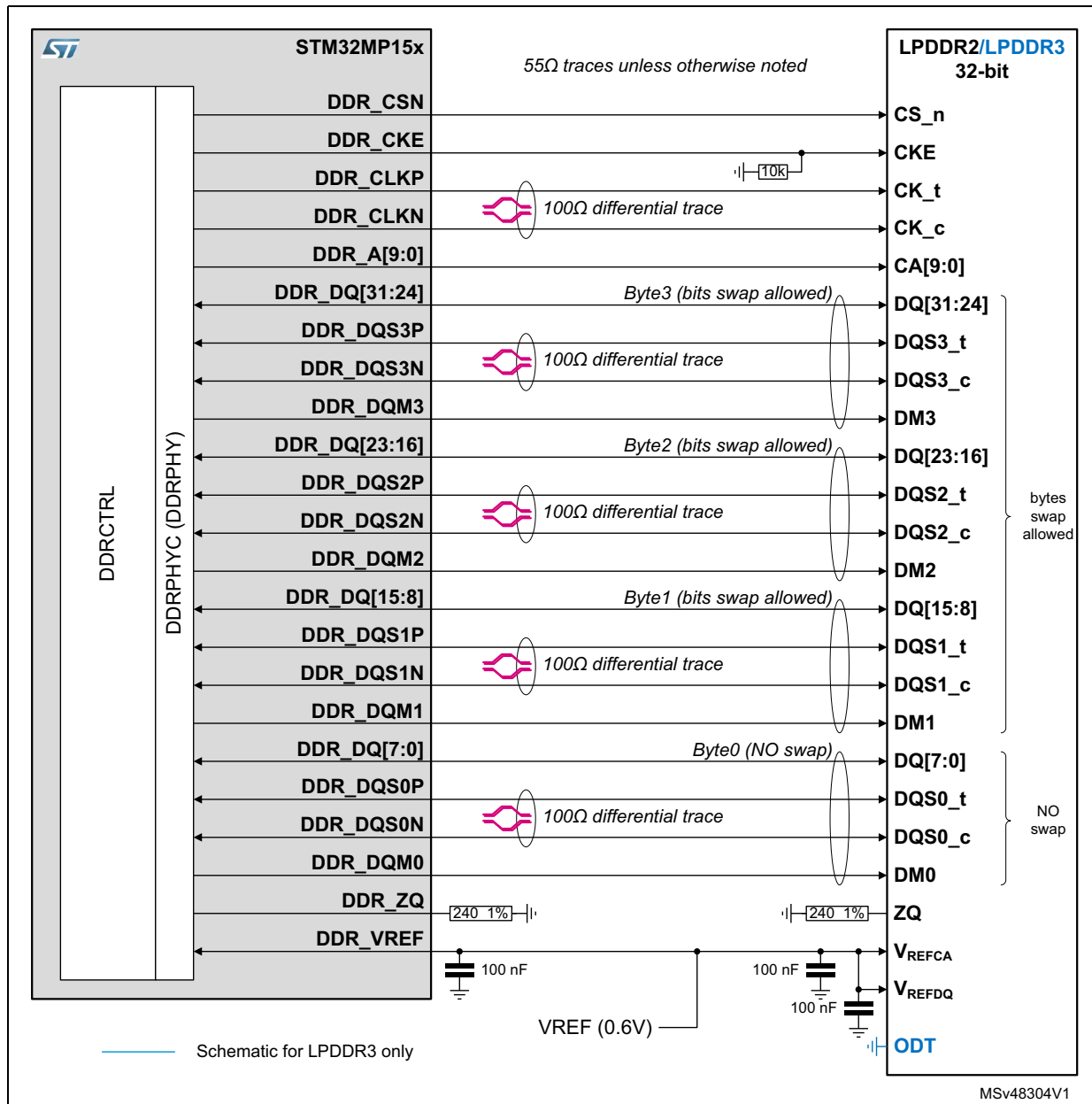

1. Supplies and decoupling capacitors not shown.

Detailed routing examples are described in *STM32MP1 Series DDR memory routing guidelines* application note (AN5122).

10.1.8 SD card

External level shifter

It allows the use of UHS-I faster modes (up to SDR50 and DDR50, that is 50 MBytes/s bus speed) which need to switch to 1.8 V card I/Os voltage (SD-card is started with 3 V card I/Os).

Note: As boot is always done in 'Standard' mode (3 V I/Os), if the card is used by the application in UHS-I, a power cycle on card supply is required after Reset or Standby.

This example is independent of MPU IO voltage V_{DD} which could be between 1.71 V and 3.6 V. In case of V_{DD} at 1.8 V typ, an external level shifter is mandatory as all SD-Card start transactions in 'Standard' mode using 3 V signaling voltage.

Note that a good signal integrity is dependent on board, GPIO strength settings (GPIO_OSPEEDR registers) and V_{DD} voltage.

When using $V_{DD} = 1.8$ V, a setting in the OTP bit and the register SYSCFG_IOCTRLSETR (HSLVEN_SDMMC bit) could be required to ensure the best speed on pads used on SDMMC outputs.

Warning: HSLVEN_xxx must not be set when V_{DD} is above 2.7 V otherwise permanent IC damage could occur.

If needed, the impedance matching resistor should be placed as close as possible of the output driver pin. Values in example below should work in most cases, but could be tailored to IO drive strengths and PCB impedance.

Figure 35. SD-Card with external level shifter connection example

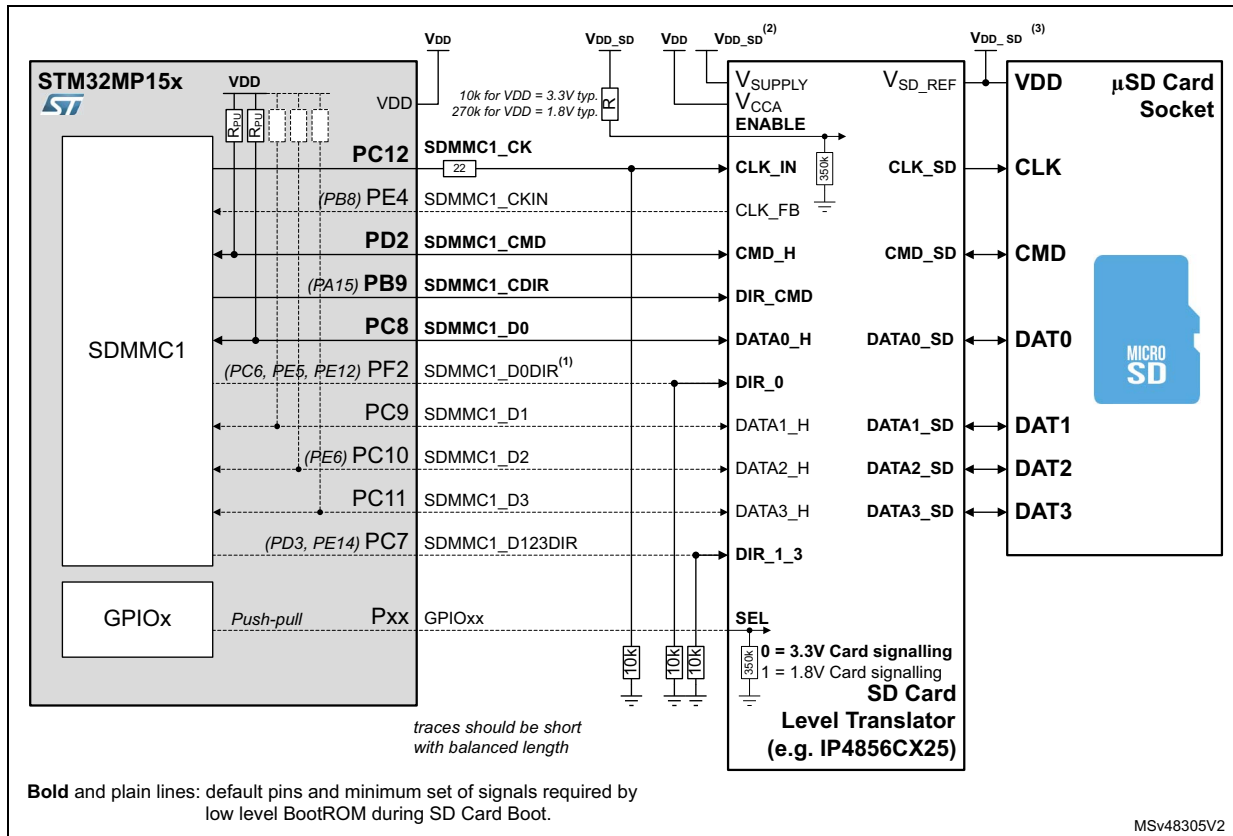

1. SDMMC1_D0DIR is not used during boot phase as only read data is requested from SD card DAT0. Nevertheless, SDMMC1_D0DIR pull-down is required to ensure correct DATA0_SD direction from card to MPU.
2. If used in USH-I, V_{DD_SD} must be cut for >1ms in order to allow reboot (on Reset or Standby exit) use V_{DD} if V_{DD} > V_{DD_SD}.
3. If used in USH-I, V_{DD_SD} must be cut for >1ms in order to allow reboot (on Reset or Standby exit).
4. Decoupling capacitors not shown.

Before V_{DD_SD} shutdown (for example before Standby), all signals going to card must be set to 0 or high-z by the SDMMC1 driver.

Direct 3.3 V IO voltage

It is the simpler interface which requires $V_{DD} > 2.9$ V, limited to standard SD-Card speed (up to high-speed 25 MBytes/s bus speed). Due to high current required by the high-density SD-card, and to limit power during Standby, the V_{DD_SD} could be separated from V_{DD} , but voltage level between them should be within 200 mV, except when V_{DD_SD} is cut to save power.

Figure 36. SD-Card with 3.3 V I/Os connection example

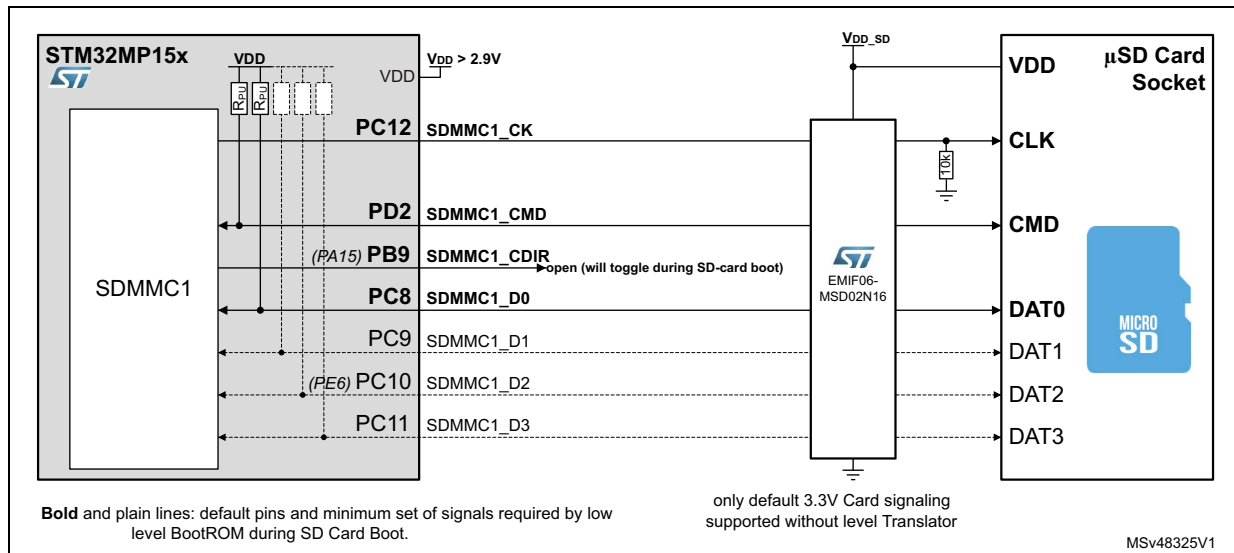

10.1.9 eMMC™ Flash

Note that a good signal integrity is dependent on board, GPIO strength settings (GPIO_OSPEEDR registers) and V_{DD} voltage. When using $V_{DD} = 1.8$ V, a setting in the OTP bit and the register SYSCFG_IOTRSETR (HSLVEN_SDMMC bit) could be required to ensure the best speed on pads used on SDMMC outputs.

Warning: HSLVEN_XXX must not be set when V_{DD} is above 2.7 V otherwise permanent IC damage could occur.

If needed, the impedance matching resistor should be placed as close as possible of the output driver pin. Values in example below should work in most cases, but could be tailored to IO drive strengths and PCB impedance.

Figure 37. eMMC™ connection example

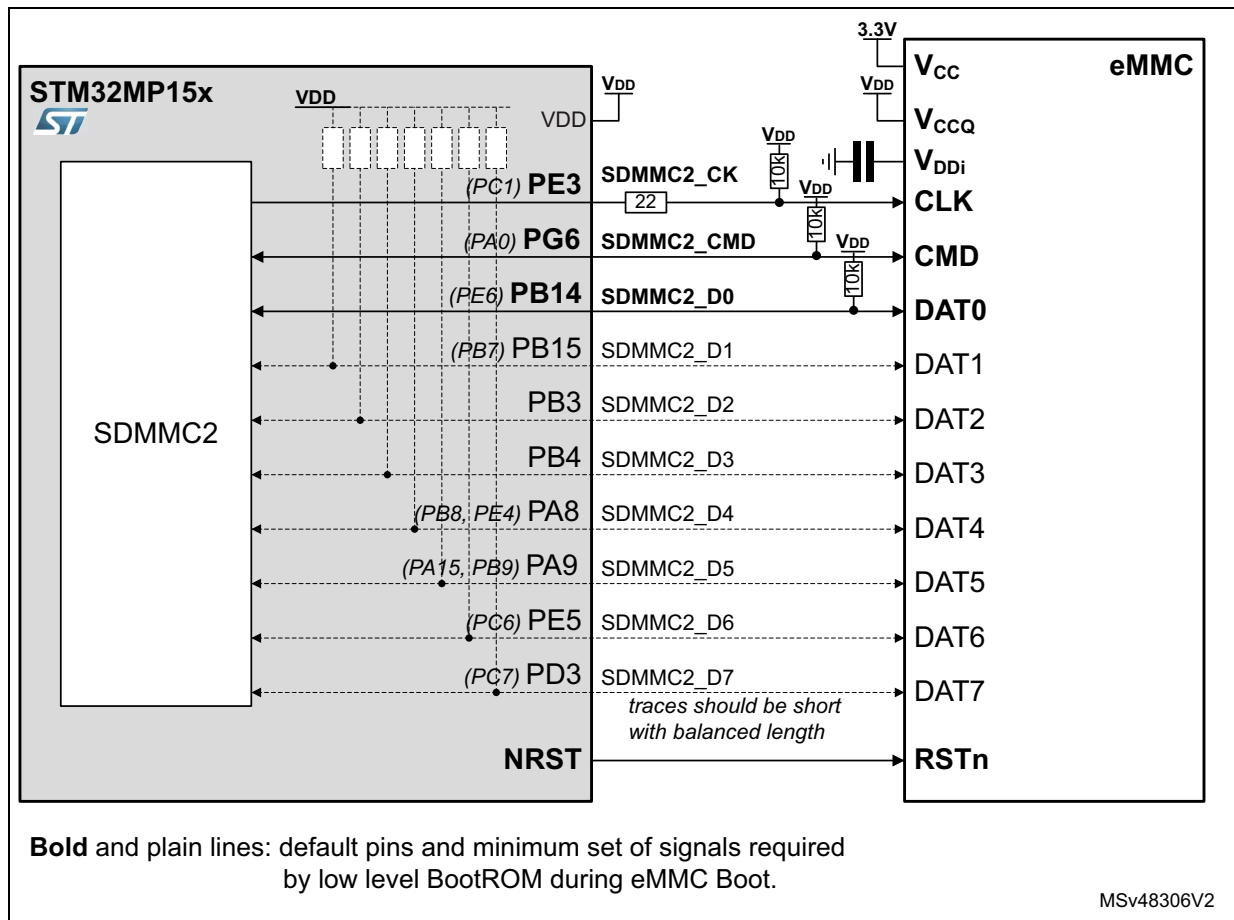

1. Decoupling capacitors not shown.

RSTn is disabled by default in eMMC and if there is no power cycle on eMMC supply, RSTn must be enabled in the eMMC registers in order to allow reboot after a reset.

In case the memory IO power supply could be shutdown independently than V_{DD}, NRST must not be directly connected to the memory reset pin and the following options could be used:

- Memory reset pin left open if the memory has an internal power on reset
- Connected through a Schottky diode with the cathode on NRST side

Otherwise, the NRST might be pulled low by memory internal protections when its IO supply is not present (which could cause an unwanted platform reset).

Refer to the memory documentation to verify the memory reset pin requirements (especially, the presence of internal power on reset and/or internal pull-up on the reset pin)

10.1.10 SLC NAND-Flash

The single 8 or 16-bit SLC NAND memory device (CE# = FMC_NCE) as well as two independent 8-bit SLC NAND memory devices (device1 CE# = FMC_NCE and device2 CE# = FMC_NCE2) are supported.

Note that boot is only done on the SLC NAND memory device connected to FMC_NCE.

Figure 38. SLC NAND-Flash connection example

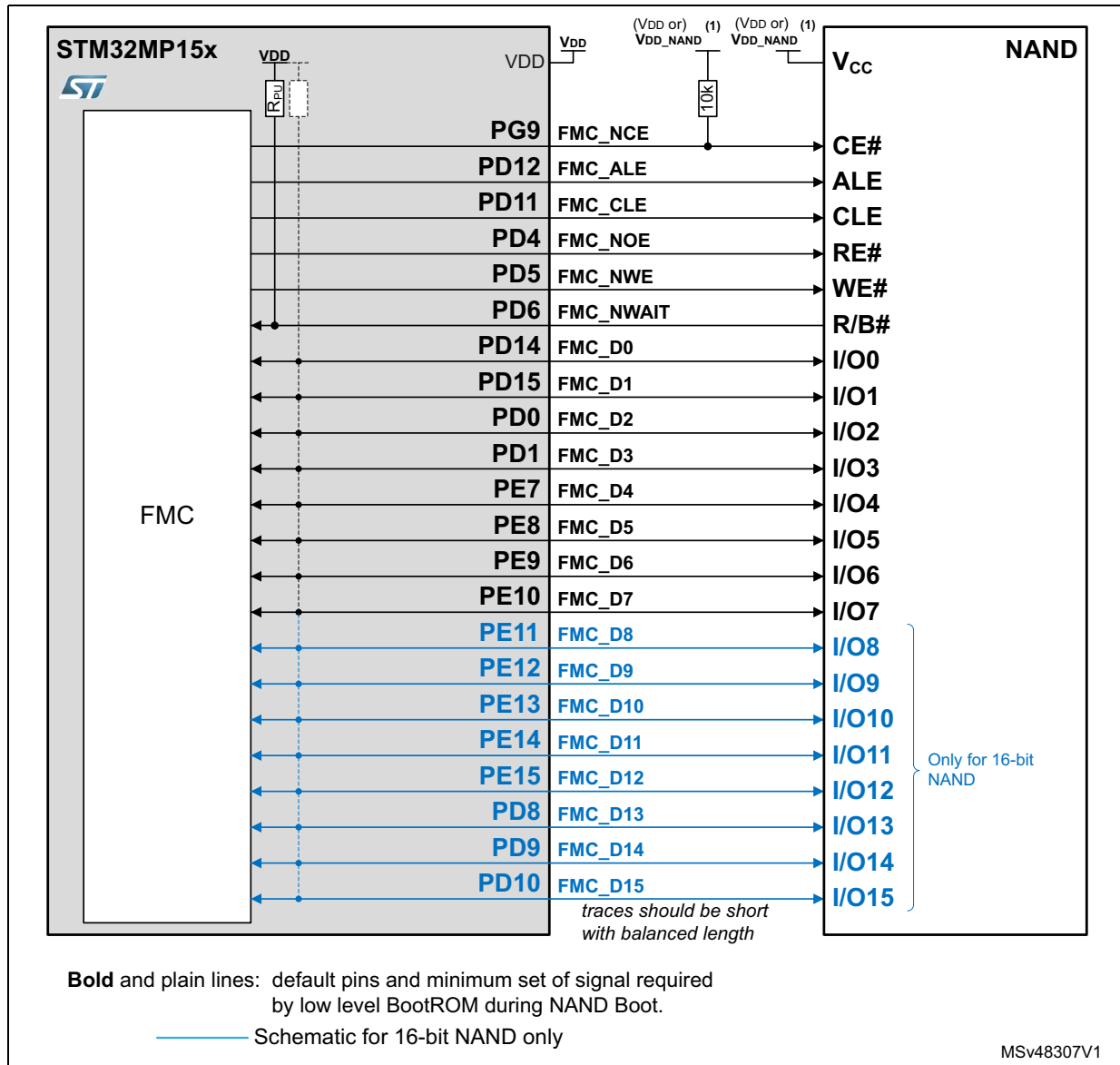

1. V_{DD_NAND} must be cut for >1ms in order to allow reboot (on Reset or Standby exit).
2. Decoupling capacitors not shown.

Note: Only single level cell (SLC) NAND-Flash is supported, with either Hamming, BCH4 or BCH8 error correction algorithms.

10.1.11 Serial NOR-Flash/NAND-Flash

Note: As boot is always done in 'SPI' mode, if the Serial Flash is set by the application in multiple data lines or if sector addressing has been changed, a power cycle on Serial Flash supply is required after Reset or Standby exit.

Note that a good signal integrity is dependent on board, GPIO strength settings (GPIO_OSPEEDR registers) and V_{DD} voltage. When using V_{DD} = 1.8 V, a setting in the OTP bit and the register SYSCFG_IOTRSETR (HSLVEN_QUADSPI bit) could be required to ensure the best speed on pads used on SDMMC outputs.

Warning: HSLVEN_xxx must not be set when V_{DD} is above 2.7 V otherwise permanent IC damage could occur.

If needed, the impedance matching resistor should be placed as close as possible of the output driver pin. Values in example below should work in most cases, but could be tailored to IO drive strengths and PCB impedance.

Figure 39. Serial Flash connection example

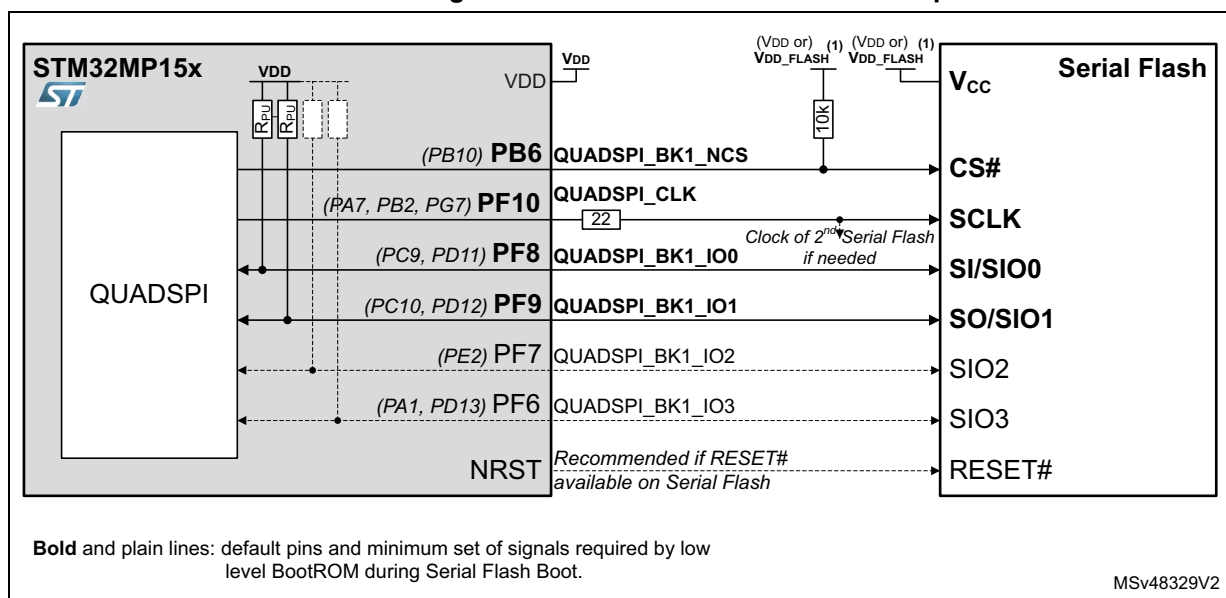

1. V_{DD_FLASH} must be cut for >1ms in order to allow reboot (on reset or Standby exit).
2. Decoupling capacitors not shown.

In case of blank or corrupted Serial Flash memory, after trying to boot from single serial Flash, the Boot ROM tries the Dual-Serial Flash mode, which means PH2 and PH3 might conflict with signals used on the board. If needed, this conflict on PH2 and PH3 could be avoided by programming OTP (Words 3, 5 and 6) to force the Boot ROM to only use the 4 pins needed in 'single serial Flash' configuration.

Figure 40. Dual-Serial Flash connection example

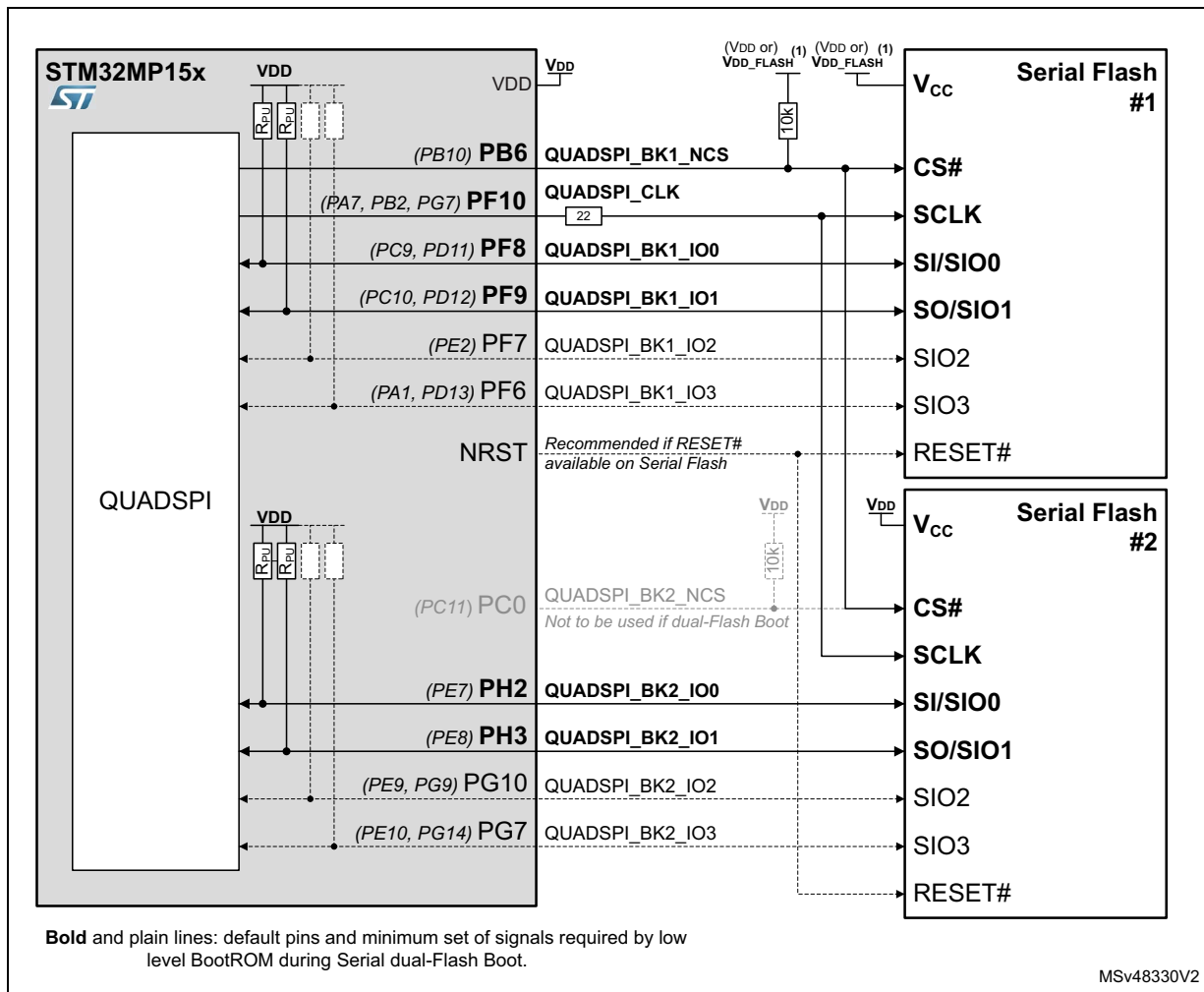

1. V_{DD_FLASH} must be cut for >1ms in order to allow reboot (on Reset or Standby exit).
2. Decoupling capacitors not shown.

In case the memory IO power supply could be shutdown independently than V_{DD} , NRST must not be directly connected to the memory reset pin and the following options could be used:

- Memory reset pin left open if the memory has an internal power on reset
- Connected through a Schottky diode with the cathode on NRST side

Otherwise, NRST might be pulled low by memory internal protections when its IO supply is not present (which could cause an unwanted platform reset).

Refer to memory documentation to verify the memory reset pin requirements (especially, the presence of internal power on reset and/or internal pull-up on the reset pin)

10.1.12 USB

Note: USB Type-C is supported with some external component, see www.st.com for dedicated application note.

A 3 kOhm 1% resistor should be connected between USB_RREF and V_{SS_USBHS} (or V_{SS} if V_{SS_USBHS} is not available on selected package).

Figure 41. USB 2 ports host high-speed + OTG full-speed connection example

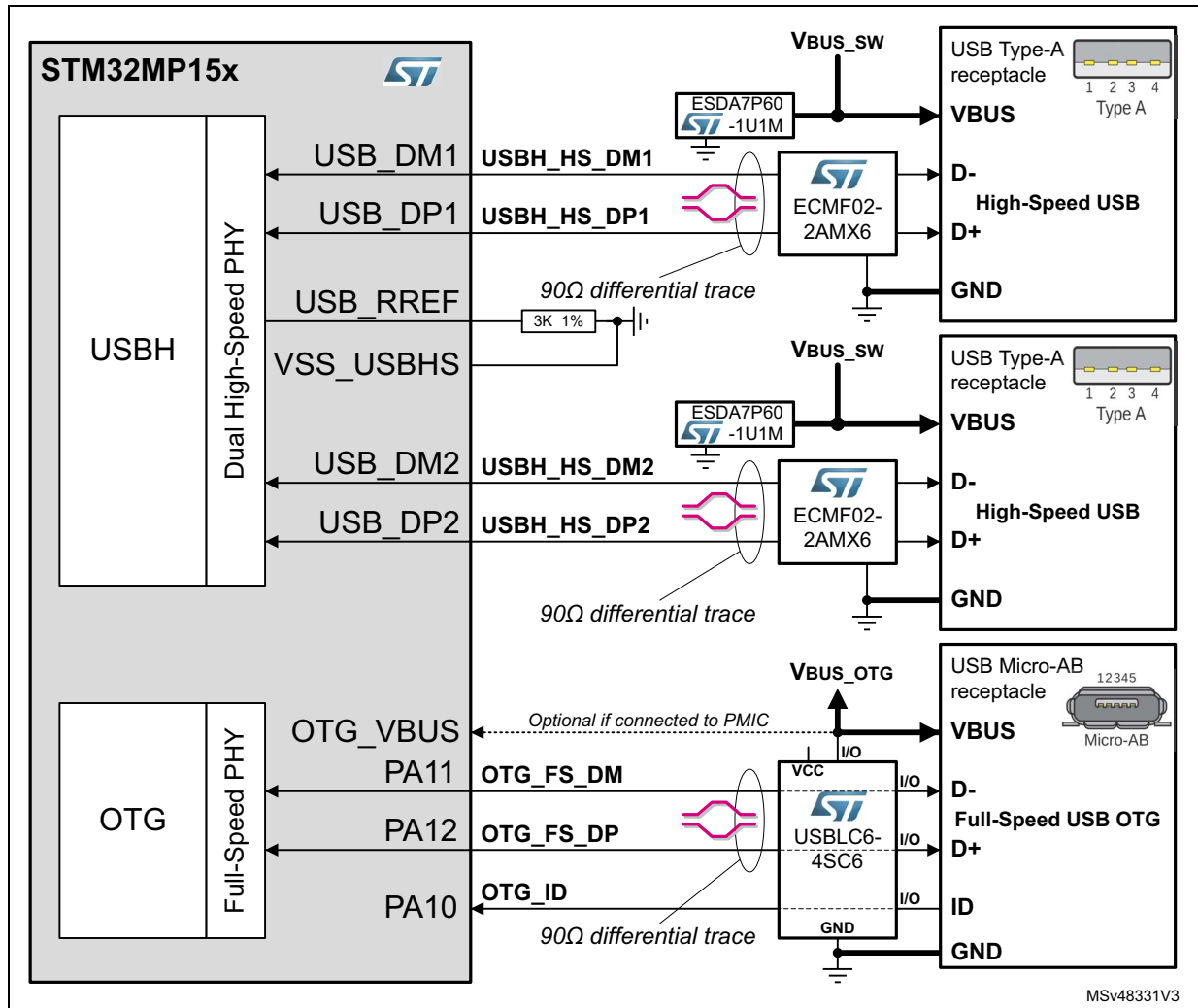

Note: On OTG IP, USB full-speed device is also supported by using Micro-B receptacle instead of Micro-AB and leaving the OTG_ID pin unconnected.

Figure 42. USB host high-speed + OTG high-speed connection example

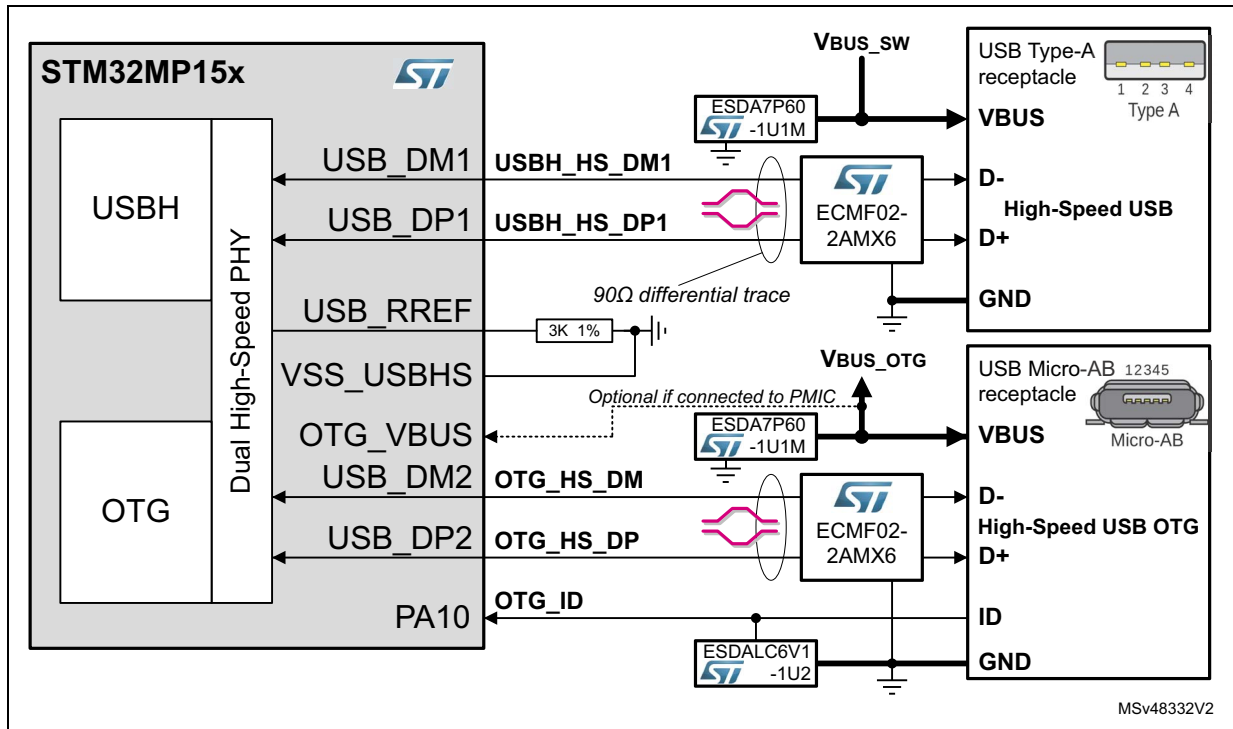

Note: On OTG IP, USB high-speed device is also supported by using Micro-B receptacle instead of Micro-AB and leaving the OTG_ID pin unconnected.

USB high-speed PCB track length matching

Each package has been optimized to provide easier length matching when differential balls pair signals are not directly on adjacent balls. Example: package with 0.8 mm ball pitch, when differential pair are on two different rows, the package already have around 800 μm length internal difference to allow the PCB track to match total length, according to USB standard requirements, with minimum or even no additional routing complexity. The table below shows DM - DP length difference (inside package) at ball level to be taken into account by the PCB tool.

Table 17. USB package length matching values

Pin name	TFBGA257		LFBGA354		TFBGA361		LFBGA448	
	(10 x 10 pitch 0.5 mm)		(16 x 16 pitch 0.8 mm)		(12 x 12 pitch 0.5 mm)		(18 x 18 pitch 0.8 mm)	
	Ball position	length difference	Ball position	length difference	Ball position	length difference	Ball position	length difference
USB_DM1	W14	486 μm	W14	818 μm	AB17	-507 μm	AB15	792 μm
USB_DP1	V14		V14		AC17		AA15	
USB_DM2	W10	494 μm	V13	-816 μm	AB16	-500 μm	AA14	-850 μm
USB_DP2	V10		W13		AC16		AB14	

Figure 43. USB high speed PCB track example for 0.8 mm ball pitch package

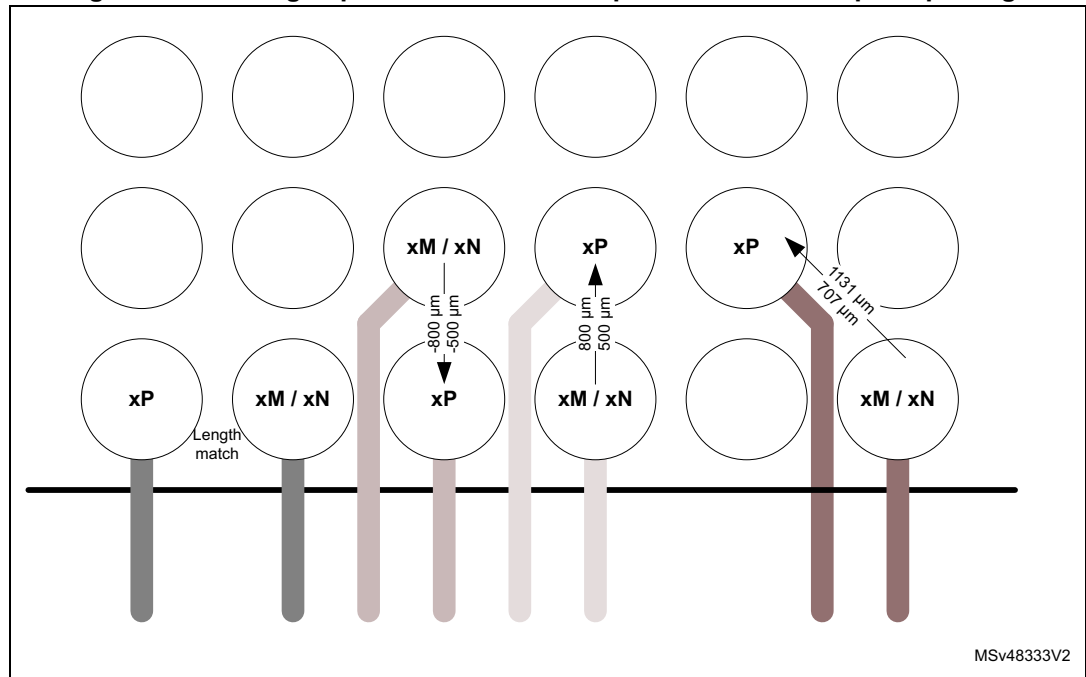

MSv48333V2

10.1.13 Ethernet

10/100M Ethernet

Note that a good signal integrity is dependent on board, GPIO strength settings (GPIO_OSPEEDR registers) and V_{DD} voltage.

If needed, the impedance matching resistors should be placed as close as possible of the output driver pin. Values in example below should work in most cases, but could be tailored to each side IO drive strengths and PCB impedance.

Figure 44. 10/100M Ethernet PHY connection example

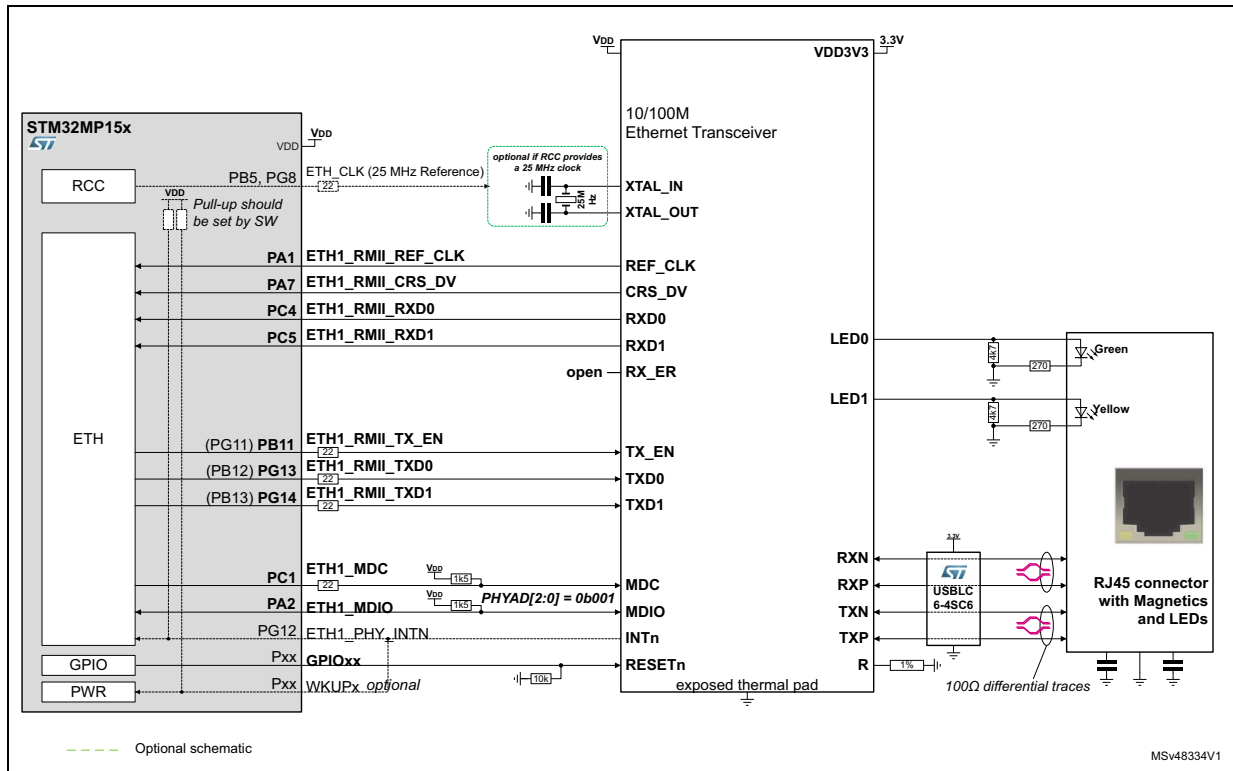

1. Decoupling capacitors not shown.

As the RCC cannot provide the 25 MHz reference clock to the PHY during low power modes, the dedicated 25 MHz crystal is required on the PHY in case wakeup on LAN (WOL) is needed for the platform.

Setting the RCC PLLs to get 25 MHz output for PHY clocking could constrain other RCC frequencies. In that case it is more flexible to put a dedicated 25 MHz crystal on the PHY.

Alternatively, if PHY allows it and if RCC can provide a precise 50 MHz clock (possibility must be checked with respect to HSE quartz frequency and RCC other peripheral/core clocks frequency settings), a 50 MHz ETH_CLK could be provided by the STM32MP15x lines to the PHY, and REF_CLK is left unconnected on both sides. This saves BOM and area, as well as some power on some PHYs.

Figure 45. 10/100M Ethernet PHY connection with REFCLK from RCC example

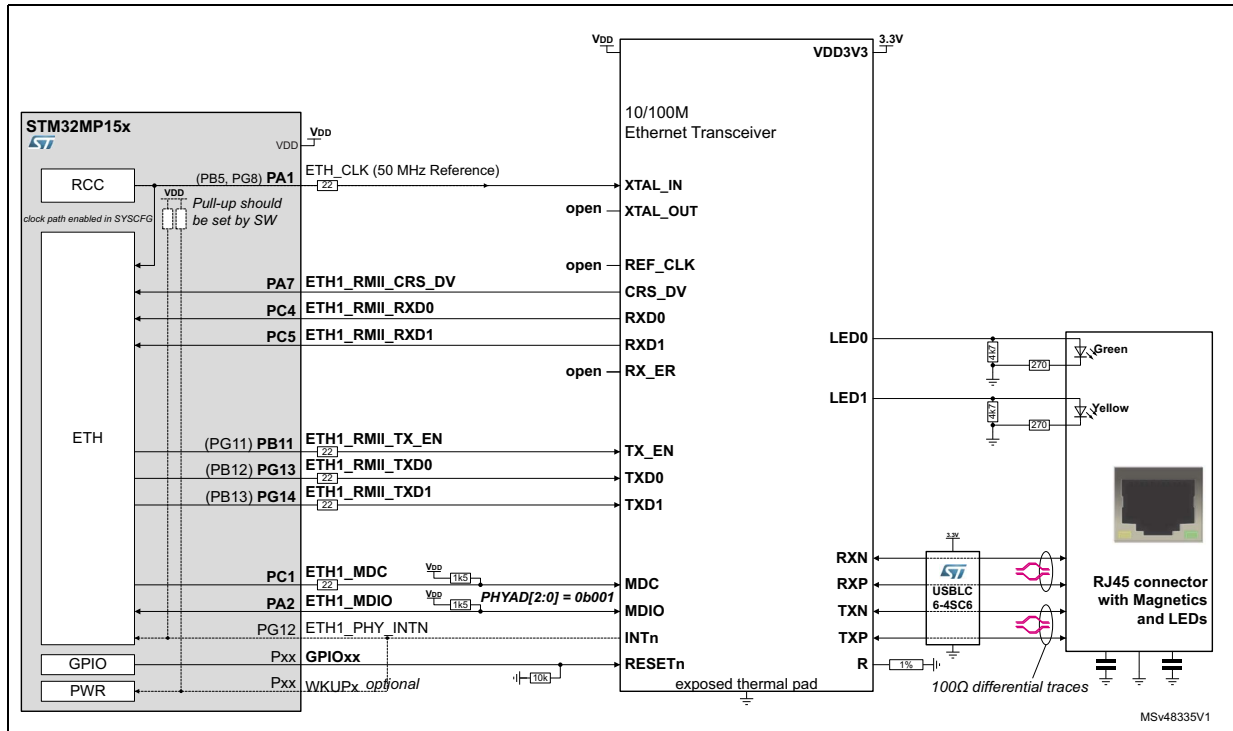

1. Decoupling capacitors not shown.

As the RCC cannot provide the 50 MHz reference clock to the PHY during low power modes, this option is not possible in case wakeup on LAN (WOL) is needed for the platform.

Setting the RCC PLLs to get 50 MHz output for PHY clocking could constrain other RCC frequencies. In that case, this option is not possible.

Gigabit Ethernet

Note that a good signal integrity is dependent on board, GPIO strength settings (GPIO_OSPEEDR registers) and V_{DD} voltage. When using $V_{DD} = 1.8\text{ V}$, a setting in the OTP bit and the register SYSCFG_IOTRSETR (HSLVEN_ETH bit) is required to ensure the best speed on pads used on Ethernet outputs.

Warning: HSLVEN_XXX must not be set when V_{DD} is above 2.7 V otherwise permanent IC damage could occur.

If needed, the impedance matching resistors should be placed as close as possible of the output driver pin. Values in example below should work in most cases, but could be tailored to each side IO drive strengths and PCB impedance.

As the RCC cannot provide the 25 MHz reference clock to the PHY during low power modes, the dedicated 25 MHz crystal is required on the PHY in case wakeup on LAN (WOL) is needed for the platform.

Setting the RCC PLLs to get 25 MHz output for PHY could constrain other RCC frequencies. In that case it is more flexible to put a dedicated 25 MHz crystal on the PHY.

Figure 46. Gigabit Ethernet PHY connection example with $V_{DD} = 3.3\text{ V}$ (RTL8211E)

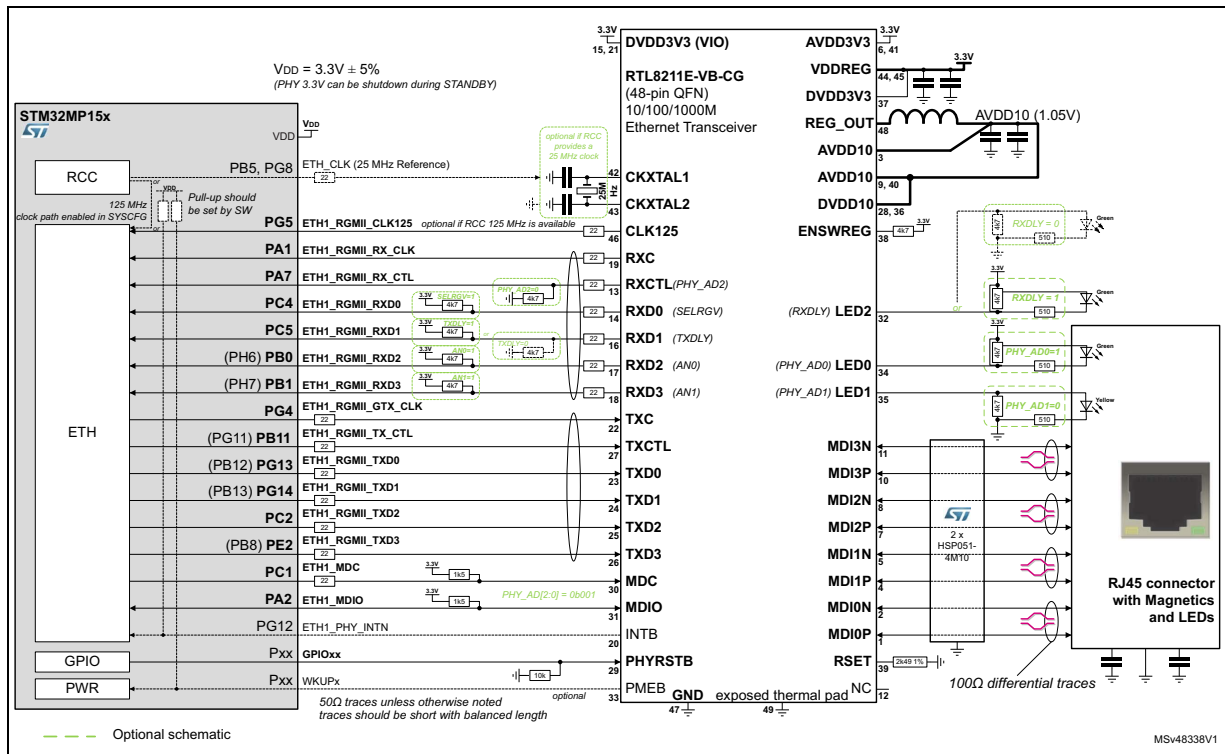

1. Decoupling capacitors not shown.

Figure 47. Gigabit Ethernet PHY connection example with $V_{DD} = 3.3\text{ V}$ (RTL8211F)

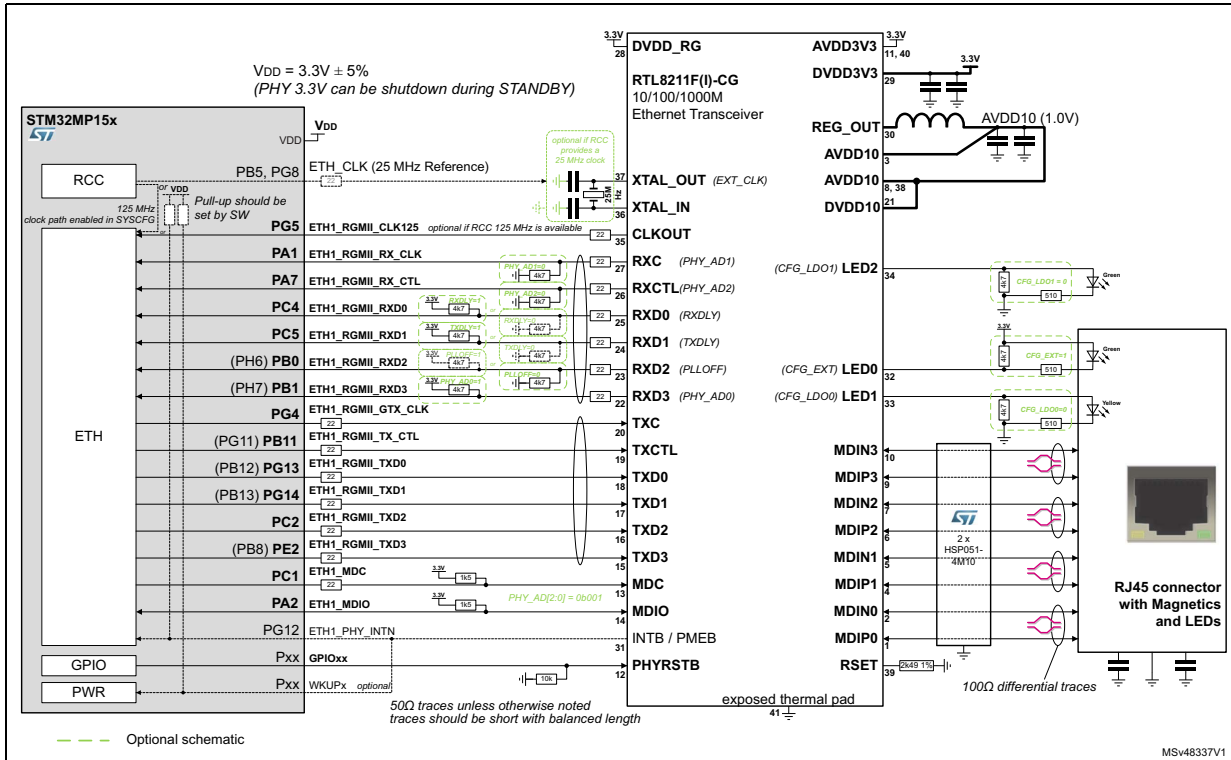

1. Decoupling capacitors not shown.

Figure 48. Gigabit Ethernet PHY connection example with $V_{DD} = 1.8\text{ V}$ (RTL8211F)

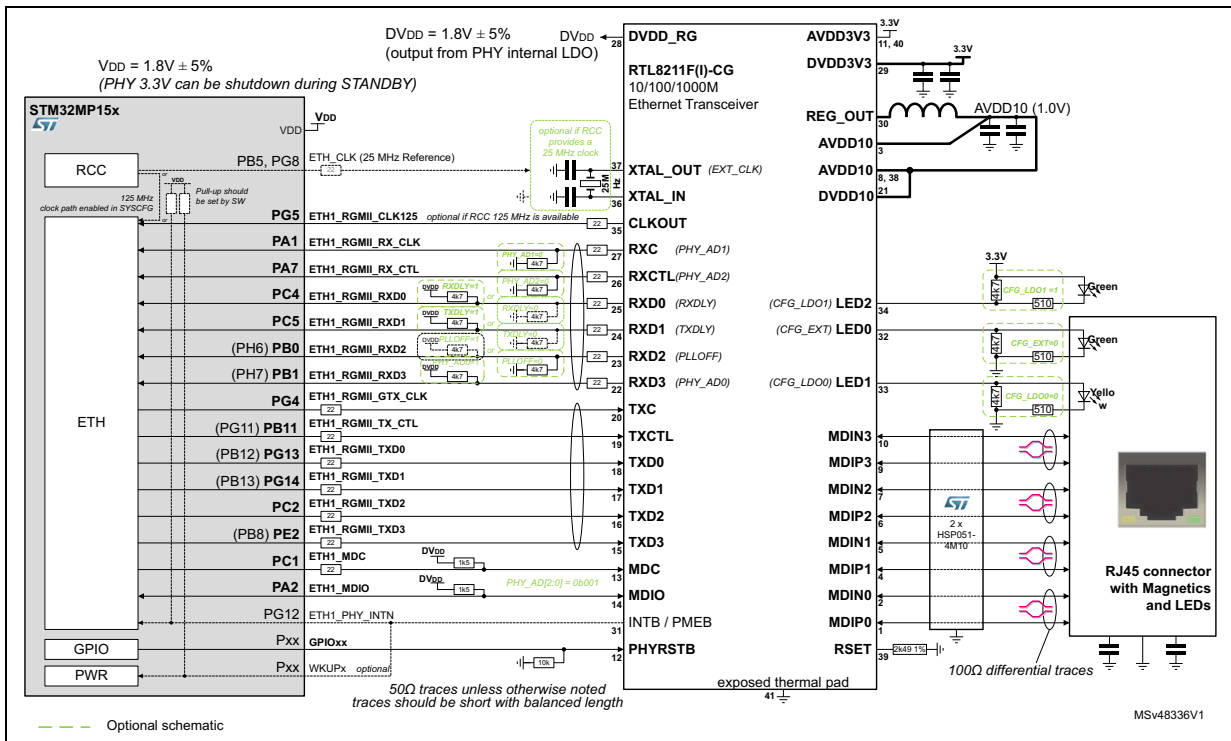

1. Decoupling capacitors not shown.

Figure 49. Gigabit Ethernet 2-port switch example with $V_{DD} = 3.3\text{ V}$ (RTL8363NB-VG)

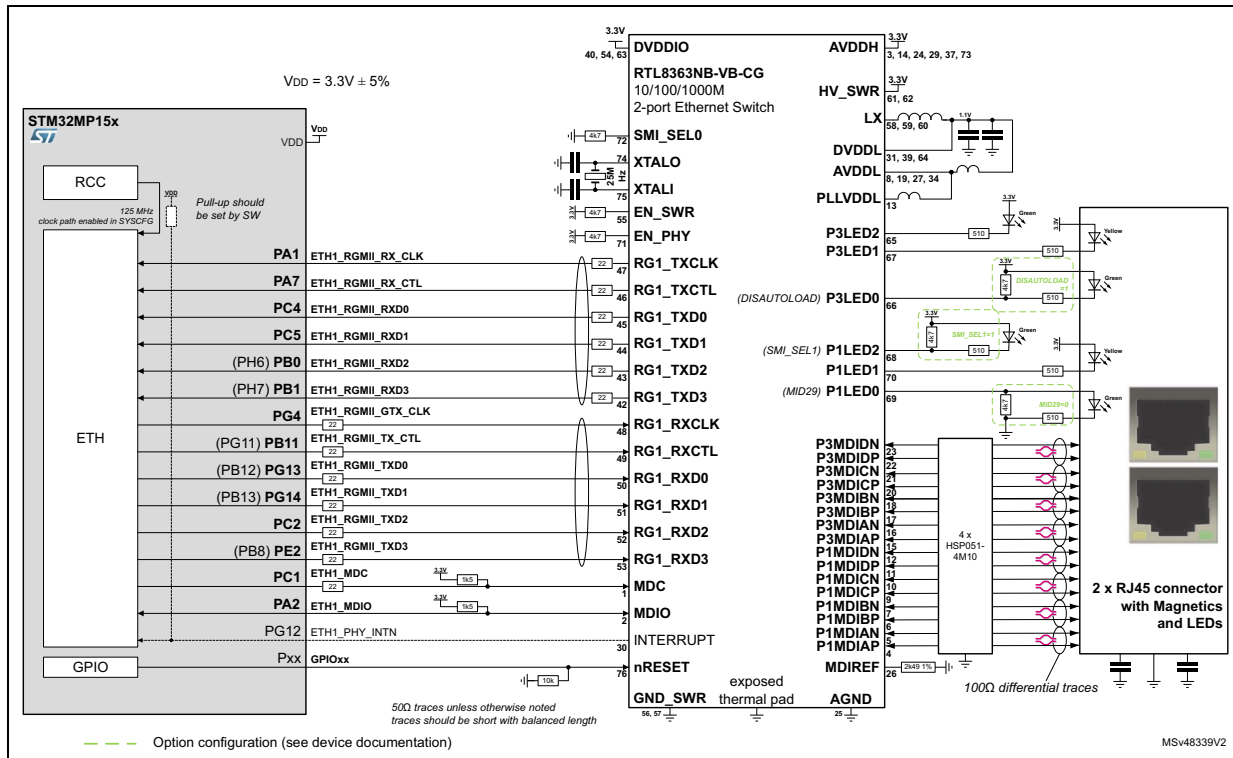

1. Decoupling capacitors not shown.

10.1.14 Display serial interface (DSI)

Figure 50. Display connection example with DSI

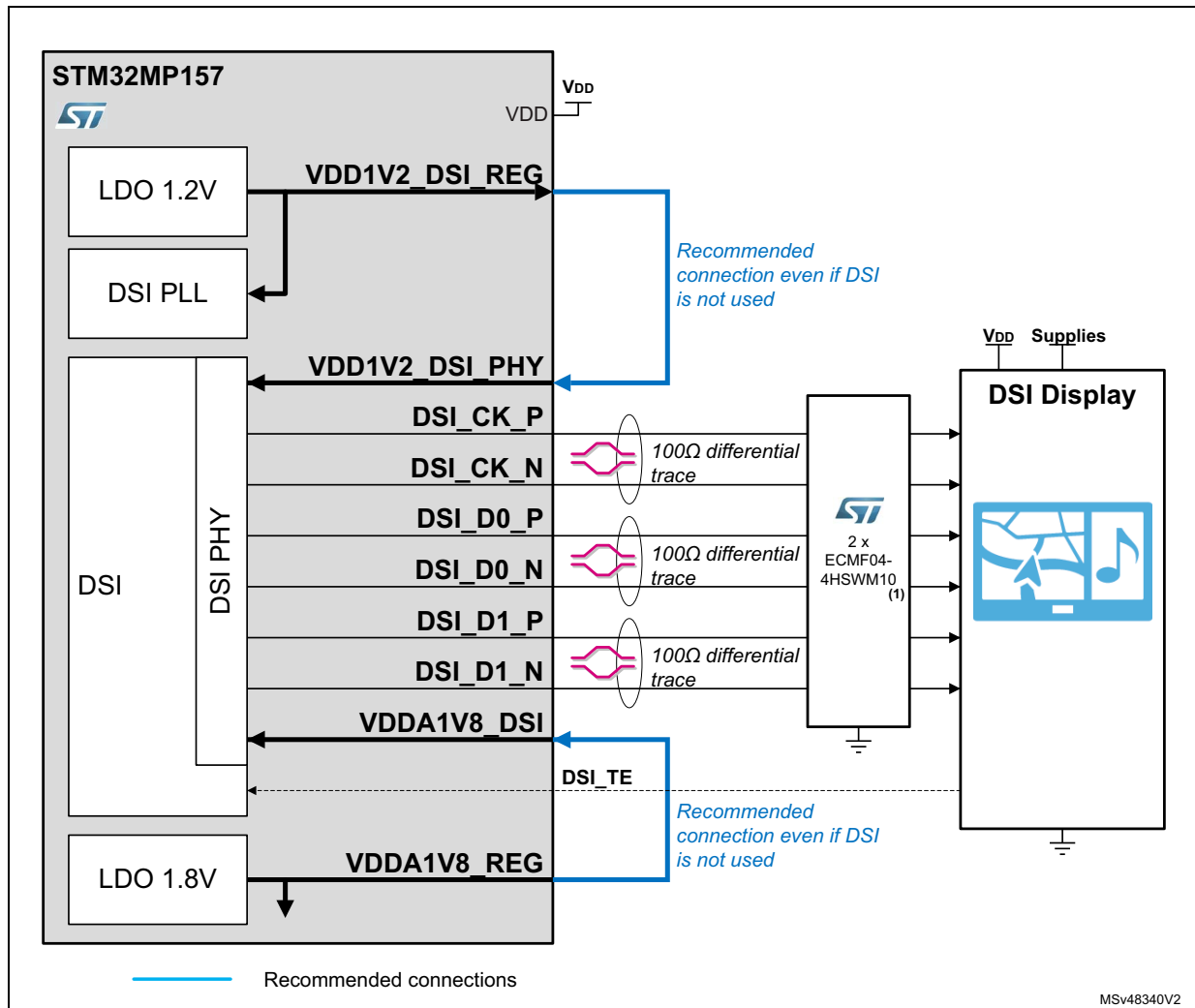

1. ECMF04-4HSWM10 includes common mode filter for WLAN/BT bands. For ESD protection only, HSP051-4M10 could be used instead (similar but not same footprint).
2. Decoupling capacitors not shown.
3. Availability of DSI depends on the STM32MP15x lines devices.

DSI interface PCB track length matching

Each package has been optimized to provide easier length matching when differential balls pair signals are not directly on adjacent balls. Example: package with 0.8 mm ball pitch, when differential pairs are on two different rows, the package already have around 800 μm length internal difference to allow the PCB track to match total length with minimum or even no additional routing complexity. [Table 18](#) shows DM - DP length difference (inside package) at ball level to be taken into account by the PCB tool.

Table 18. DSI package length matching values

Pin name	TFBGA257		LFBGA354		TFBGA361		LFBGA448	
	(10 x 10 pitch 0.5 mm)		(16 x 16 pitch 0.8 mm)		(12 x 12 pitch 0.5 mm)		(18 x 18 pitch 0.8 mm)	
	Ball position	Length difference	Ball position	Length difference	Ball position	Length difference	Ball position	Length difference
DSI_CKN	B12	-505 μm	A14	822 μm	A16	490 μm	A16	867 μm
DSI_CKP	A12		B14		B16			
DSI_D0N	C12	-736 μm	A13	781 μm	B15	514 μm	A15	791 μm
DSI_D0P	B11		B13		C15		B15	
DSI_D1N	B13	-507 μm	A15	804 μm	A17	505 μm	A17	785 μm
DSI_D1P	A13		B15		B17		B17	

Figure 51. DSI interface PCB track example for 0.8 mm ball pitch package

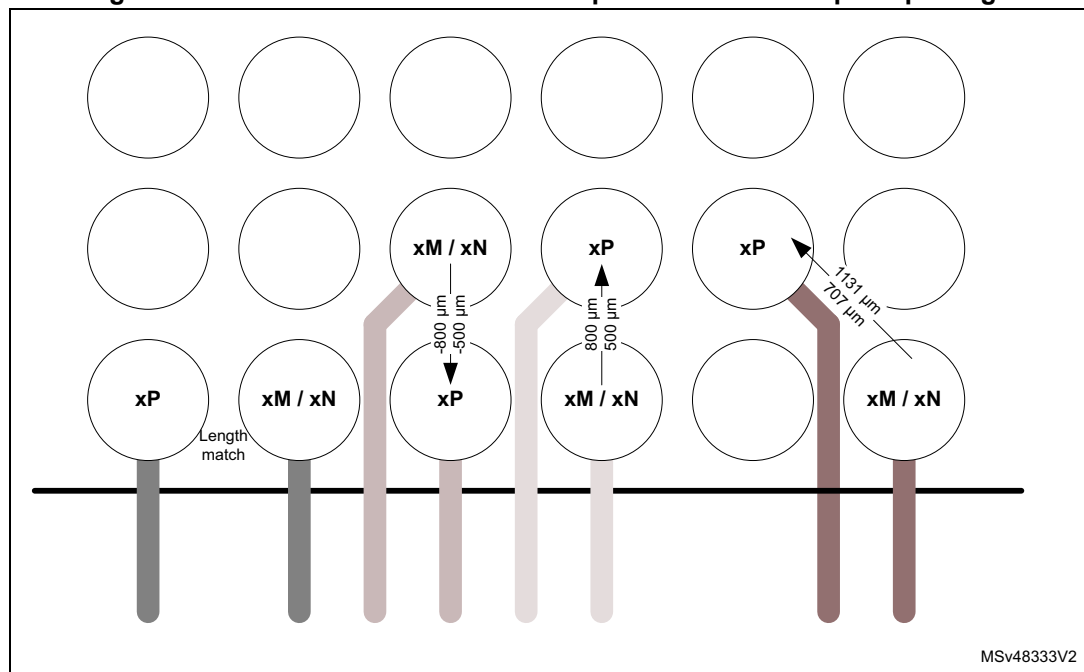

Table 19. DSI PCB routing recommendations

Recommendation	Min	Typ	Max	Unit
Differential impedance	90	100	110	Ω
Single-ended impedance	45	50	55	Ω
Length matching within a pair (including package)	-5	-	+5	mils
	-0.127	-	+0.127	mm
Length matching between pairs	-200	-	+200	mils
	-5.08	-	+5.08	mm
Max link length (including display cables)	-	-	8	inches
	-	-	203	mm
Max number of vias (recommended value)	-	-	2	-
Distance between any differential trace and other signals	S-2S	S-3S or more		_(1)
Do no route over power plane split. No stubs (point to point only). No right angles				

1. Definition can be found for instance in *STM32MP1 Series DDR memory routing guidelines* application note (AN5122).

11 Revision history

Table 20. Document revision history

Date	Revision	Changes
01-Feb-2019	1	Initial release.
14-Apr-2020	2	<p>Updated:</p> <ul style="list-style-type: none"> – Cover replacing STM32MP1 Series by STM32MP151, STM32MP153 and STM32MP157 lines. – Table 1: Reference documents. – Section 4.1: Introduction USB supplies. – Section 4.2: Power supply schemes. – Table 4: Amount of decoupling recommendation by package. – Figure 8: 12x12 TFBGA361 compatibility. – Figure 30: Discrete supplies example 3.3 V I/Os with DDR3L. – Figure 31: PMIC example 3.3 V I/Os with DDR3L. – Figure 41: USB 2 ports host high-speed + OTG full-speed connection example. – Figure 49: Gigabit Ethernet 2-port switch example with VDD = 3.3 V (RTL8363NB-VG). <p>Removed:</p> <ul style="list-style-type: none"> – ‘ST1S31PUR SMPS details’ figure. – ‘Components example for 1.2 V 2A’ table. – ‘Components example for 1.35 V 1A’ table.
14-Jan-2021	3	<p>Updated:</p> <ul style="list-style-type: none"> – Table 6: Major feature changes related to packages. – Section 4.3.3: Application and system resets. – Figure 4: Simplified reset pin circuit. – Section 7.3: Embedded boot loader mode. – Table 12: Boot modes. – Figure 30: Discrete supplies example 3.3 V I/Os with DDR3L. – Figure 31: PMIC example 3.3 V I/Os with DDR3L. – Figure 32: PMIC example 1.8 V I/Os with LPDDR2/LPDDR3. – Section 10.1.11: Serial NOR-Flash/NAND-Flash. – Section 10.1.13: Ethernet. – Section 10.1.14: Display serial interface (DSI).

IMPORTANT NOTICE – PLEASE READ CAREFULLY

STMicroelectronics NV and its subsidiaries (“ST”) reserve the right to make changes, corrections, enhancements, modifications, and improvements to ST products and/or to this document at any time without notice. Purchasers should obtain the latest relevant information on ST products before placing orders. ST products are sold pursuant to ST’s terms and conditions of sale in place at the time of order acknowledgement.

Purchasers are solely responsible for the choice, selection, and use of ST products and ST assumes no liability for application assistance or the design of Purchasers’ products.

No license, express or implied, to any intellectual property right is granted by ST herein.

Resale of ST products with provisions different from the information set forth herein shall void any warranty granted by ST for such product.

ST and the ST logo are trademarks of ST. For additional information about ST trademarks, please refer to www.st.com/trademarks. All other product or service names are the property of their respective owners.

Information in this document supersedes and replaces information previously supplied in any prior versions of this document.

© 2021 STMicroelectronics – All rights reserved